

# HERMETIC COMPRESSORS



## **Embraco Europe Compressors Handbook**

 **Embraco** aspera



This handbook on hermetic compressors is designed for those working in the refrigeration field, whom already know the basic techniques of domestic and commercial refrigeration, and air conditioning. It is intended to be a guide in the selection of Embraco Europe compressors and their correct application.

## GENERAL INDEX

1	<b>TECHNICAL DOCUMENTS</b>	11
1.1	GENERAL CATALOG	11
1.2	GENERAL GUIDE OF COMPRESSORS	11
1.3	TECHNICAL BULLETIN	11
1.4	ELECTRICAL COMPONENT CATALOG	12
1.5	COMPRESSOR HANDBOOK	12
1.6	ELECTRONIC CATALOG	12
2	<b>GENERAL INFORMATION</b>	13
2.1	COMPRESSOR RANGES	13
	Table 1 <i>Compressor Series - Application - Refrigerants</i> .....	13
2.2	APPLICATIONS	13
	Table 2 <i>Applications</i> .....	13
2.3	STARTING TORQUE CLASSIFICATION	14
	Table 3 <i>Electrical motor starting torque classification</i> .....	14
2.4	ELECTRIC MOTOR TYPES	14
	Table 4 <i>Electrical motor types</i> .....	14
2.5	VOLTAGES & FREQUENCIES	15
	Table 5 <i>Voltages &amp; Frequencies</i> .....	15
2.6	COMPRESSOR ELECTRICAL COMPONENTS	16
	Table 6 <i>Electrical components</i> .....	16
2.7	COMPRESSOR COOLING TYPES	16
	Table 7 <i>Cooling Types</i> .....	16
2.8	COMPRESSOR NAMEPLATES - IDENTIFICATION DATA	17
	Figure 1 <i>Metallic Nameplates (used up to 2001)</i> .....	17
	Figure 2 <i>Adhesive Nameplates</i> .....	17
	Figure 3 <i>Series NB/NE - Adhesive Nameplates (used up to 2003)</i> .....	18
	Figure 4 <i>Series BP - Adhesive Nameplates (used up to 2004)</i> .....	18
	Figure 5 <i>Series EM - Adhesive Nameplates</i> .....	18

Figure 6a	<i>Compressor Model Identification Code</i> .....	19
Figure 6b	<i>Series EM - Compressor Model Identification Code</i> .....	20
Figure 7	<i>Compressor Bill of Materials Code</i> .....	21
Figure 8	<i>Manufacturing Date Code</i> .....	21
2.9	<b>WIRING DIAGRAMS</b> .....	22
Table 8	<i>Wiring Diagram</i> .....	23
2.9.1	Compressor Wiring Diagram - EM Series - RSIR .....	24
Figure 9	<i>RSIR Version terminal board with PTC starting device</i> .....	24
2.9.2	Compressor Wiring Diagram BP-NB Series – RSIR-RSCR .....	24
Figure 10	<i>RSIR and RSCR Standard Version</i> .....	24
2.9.3	Compressor Wiring Diagram BP-T-NB-NE Series (electrical components without terminal board) – RSIR-CSIR .....	25
Figure 11	<i>RSIR and CSIR standard version</i> .....	25
2.9.4	Compressor Wiring Diagram T Series (electrical component with terminal board) – RSIR-CSIR .....	25
Figure 12	<i>RSIR - CSIR terminal board version</i> .....	25
2.9.5	Compressor Wiring Diagram NB-NE Series (electrical component with terminal board) – RSIR-CSIR .....	26
Figure 13	<i>RSIR and CSIR terminal board version</i> .....	26
2.9.6	Compressor Wiring Diagram NB Series (electrical component with terminal board) – RSIR-RSCR .....	26
Figure 14	<i>RSIR and RSCR terminal board version with PTC starting device</i> .....	26
2.9.7	Compressor Wiring Diagram T-J Series – PSC-CSR .....	27
Figure 15	<i>PSC and CSR Versions</i> .....	27
2.9.8	Compressor Wiring Diagram NE-T-J Series – CSR BOX .....	27
Figure 16	<i>CSR BOX with internal or external overload protector</i> .....	27
2.9.9	Compressor Wiring Diagram T-J Series – CSIR .....	28
Figure 17	<i>Standard CSIR (with the relay T.I. 3CR or G.E. 3ARR2)</i> .....	28
2.9.10	Compressor Wiring Diagram T-J Series – CSIR BOX .....	28
Figure 18	<i>CSIR BOX (with relay T.I. 3CR or G.E. 3ARR2)</i> .....	28
2.9.11	Compressor Wiring Diagram J Series – CSIR BOX .....	29
Figure 19	<i>CSIR BOX (with relay G.E. 3ARR3 or AMF RVA)</i> .....	29
2.9.12	<b>THREE PHASE</b> .....	29
Figure 20	<i>Three Phase</i> .....	29
3	<b>COMPRESSOR SUPPLY CONDITIONS</b> .....	30
3.1	<b>ELECTRICAL INSULATION</b> .....	30
3.2	<b>“IP” DEGREE OF PROTECTION</b> .....	30
Table 9	<i>IP Degree</i> .....	30
3.3	<b>THE COMPRESSOR SHELL HYDROSTATIC STRENGTH</b> .....	30
3.4	<b>DEHYDRATION</b> .....	31
Table 10	<i>Maximum level of residual humidity</i> .....	31
3.5	<b>PAINTING</b> .....	31

3.6	<b>COMPRESSOR PRESSURISATION</b>	31
3.7	<b>OIL CHARGE</b>	31
Table 11	<i>Lubricant oils used in the compressors</i> .....	32
3.8	<b>MINIMUM QUANTITY OF LUBRICANT</b>	32
Table 12	<i>Minimum quantity of oil</i> .....	32
3.9	<b>SPECIAL VERSIONS</b>	33
Table 13	<i>Special Version Examples</i> .....	33
4	<b>COMPRESSOR PACKAGING</b>	34
4.1	<b>MULTIPLE CARTON DISPOSABLE PACKAGE</b>	34
Table 14	<i>Characteristics of carton multiple packages</i> .....	34
Figure 21	<i>One Box + Shipping Skid</i> .....	34
Figure 22	<i>Two Boxes + Shipping Skid</i> .....	34
4.1.1	<b>Compressor Identification Marks</b> .....	35
Figure 23	<i>Package Label</i> .....	35
4.2	<b>RETURNABLE WOOD PACKAGE</b>	36
Table 15	<i>Characteristics of returnable multiple wood packages</i> .....	36
Figure 25	<i>“EM” (120 compressors)</i> .....	36
Figure 26	<i>“EM” (100 compressors)</i> .....	37
Figure 27	<i>“NB” (80 compressors)</i> .....	37
4.2.1	<b>Compressor identification marks</b> .....	37
4.3	<b>PACKAGE FOR ELECTRICAL COMPONENTS AND ACCESSORIES</b>	38
Figure 28	<i>Components packing label</i> .....	38
4.4	<b>SINGLE PACKAGE</b>	39
Figure 29	<i>Single Compressor Package</i> .....	39
5	<b>HANDLING, TRANSPORTING AND STORING COMPRESSORS</b>	40
5.1	<b>HANDLING</b>	40
5.2	<b>TRANSPORTING</b>	40
5.2.1	<b>Shipment by container</b> .....	40
Table 16	<i>Load Characteristics for 20' container</i> .....	41
5.2.2	<b>Shipments by truck</b> .....	41
Table 17	<i>Characteristics of load by truck</i> .....	41
5.3	<b>ACCEPTABLE COMPRESSOR POSITIONS DURING TRANSPORTATION</b>	42
Table 18	<i>Acceptable compressor position during transportation</i> .....	42
5.4	<b>STORAGE</b>	43
Table 19	<i>Maximum height for multiple throwaway carton packages</i> .....	43
Table 20	<i>Maximum height for multiple returnable packages</i> .....	44

6	<b>INFORMATION ABOUT CORRECT COMPRESSOR INSTALLATION</b>	45
6.1	<b>COMPRESSOR SELECTION</b>	45
6.1.1	Minimum evaporating temperature .....	45
6.1.2	Refrigeration capacity .....	45
6.1.3	Refrigerant type .....	45
6.1.4	Ambient temperature .....	45
6.1.5	Operating Voltages and Frequencies .....	46
6.1.6	Electric motor starting torque .....	46
6.1.7	Compressor cooling type .....	46
6.1.8	Noise level .....	46
6.1.9	Maximum current input .....	46
6.2	<b>COMPRESSOR UNPACKING</b>	46
6.3	<b>PREPARATION OF REFRIGERATING SYSTEM COMPONENTS</b>	47
6.4	<b>REFRIGERANT USE GUIDE</b>	48
6.4.1	Guide for the use of R134a .....	49
	Table 21 <i>R134a Physical Characteristics</i> .....	49
	Table 22 <i>R134a Ecological Characteristics</i> .....	49
6.4.2	Guide for the use of R600a .....	52
	Table 23 <i>R600a Physical characteristics</i> .....	52
	Table 24 <i>R 600a Ecological Characteristics</i> .....	52
6.4.3	Guide for the use of R404A .....	54
	Table 25 <i>R 404A Physical Characteristics</i> .....	54
	Table 26 <i>R 404A Ecological Characteristics</i> .....	54
6.4.4	Guide for the use of R407C .....	57
	Table 27 <i>R 407C Physical Characteristics</i> .....	57
	Table 28 <i>R 407C Ecological Characteristics</i> .....	57
6.4.5	Guide for the use of R290 .....	60
	Table 29 <i>R290 Physical Characteristics</i> .....	60
	Table 30 <i>R290 Ecological Characteristics</i> .....	60
6.5	<b>FILTER DRYER</b>	62
	Table 31 <i>Suggested Filter Dryer</i> .....	62
	Table 32 <i>Inconvenient caused by moisture in the system</i> .....	62
6.6	<b>CAPILLARY TUBES</b>	63
	Table 33 <i>Choice of Capillary</i> .....	63
6.7	<b>APPLICATION OF RUBBER GROMMETS</b>	70
	Figure 30 <i>Rubber Grommets Assembling Process</i> .....	70
	Table 34 <i>Rubber Grommets</i> .....	71
	Figure 31 <i>Rubber Grommets</i> .....	71
6.8	<b>WELDING OF CONNECTION TUBES</b>	73
6.9	<b>ROTALOCK VALVES</b>	73

	Table 35	<i>Suggested tightening torques</i> .....	74
	Figure 32	<i>Rotalock Valve</i> .....	74
	Figure 33	<i>Valve Position</i> .....	75
6.10		COMPRESSOR COOLING	75
	Table 36	<i>Fan Coolers Characteristics</i> .....	75
6.11		VACUUM OPERATIONS	76
6.12		REFRIGERANT CHARGE	76
	Table 37	<i>Maximum Refrigerant Charge</i> .....	76
6.13		REFRIGERANT LEAKS CONTROL	77
6.14		ELECTRIC SUPPLY	77
7		<b>RUNNING DATA AND COMPRESSOR CHECKING PROCEDURES</b>	78
7.1		COMPRESSOR RUNNING LIMITS	78
7.1.1		Maximum temperature of electric motor stator windings .....	78
7.1.2		Discharge gas maximum temperature .....	79
7.1.3		Discharge gas maximum pressures .....	79
	Table 38	<i>Discharge gas maximum pressures</i> .....	79
7.1.4		Suction gas overheating .....	79
7.1.5		Compressor operating fields .....	80
7.1.6		Start conditions .....	82
	Table 39	<i>Pressure limit value</i> .....	82
7.1.7		Oil cooler temperatures .....	82
7.1.8		Running time .....	83
7.1.9		Cycling .....	83
7.2		COMPRESSOR CONTROL PROCEDURES	83
7.3		TROUBLESHOOTING AND SERVICE CHART	83
	Table 40	<i>Troubleshooting and service chart</i> .....	84
7.4		ELECTRIC CIRCUITS CONTROL	87
7.4.1		Standard version RSIR - RSCR EM Series with PTC starting device .....	87
7.4.2		Standard version RSIR - RSCR BP Series with PTC starting device .....	88
7.4.3		Standard version RSIR NB - NE - T Series with electromagnetic current relay .....	88
7.4.4		Standard version CSIR NB - NE - T Series with electromagnetic current relay .....	89
7.4.5		Terminal board version RSIR NB - NE - T Series with electromagnetic current relay .....	90
7.4.6		Terminal board version CSIR NB - NE - T Series with electromagnetic current relay .....	90
7.4.7		Terminal board version RSIR and RSCR NB Series with PTC starting device .....	91
7.4.8		Standard version PSC NE - T - J Series .....	92
7.4.9		Standard versions CSR - CSR BOX NE - T - J Series with potential current relay .....	92
7.4.10		Standard versions CSIR and CSIR BOX T and J Series with current electromagnetic relay ....	93
7.4.11		Standard version CSIR J Series with current electromagnetic relay .....	94
7.4.12		Three-Phase Version J .....	94

7.5	<b>CONTROL PROCEDURES</b>	95
7.5.1	Control of electric motor stator windings .....	95
7.5.2	Control of stator windings ohmic resistance .....	95
7.5.3	Control of start and run capacitors .....	95
8	<b>HOW TO RETURN SUPPLIED PRODUCTS TO EMBRACO EUROPE</b>	96
8.1	<b>CONDITIONS</b>	96
8.2	<b>TESTS ON THE CUSTOMER APPLICATIONS</b>	97



## INDEX OF FIGURES

Figure 1	<i>Metallic Nameplates (used up to 2001)</i>	17
Figure 2	<i>Adhesive Nameplates</i>	17
Figure 3	<i>Series NB/NE - Adhesive Nameplates (used up to 2003)</i>	18
Figure 4	<i>Series BP - Adhesive Nameplates (used up to 2004)</i>	18
Figure 5	<i>Series EM - Adhesive Nameplates</i>	18
Figure 6a	<i>Compressor Model Identification Code</i>	19
Figure 6b	<i>Series EM - Compressor Model Identification Code</i>	20
Figure 7	<i>Compressor Bill of Materials Code</i>	21
Figure 8	<i>Manufacturing Date Code</i>	21
Figure 9	<i>RSIR Version terminal board with PTC starting device</i>	24
Figure 10	<i>RSIR and RSCR Standard Version</i>	24
Figure 11	<i>RSIR and CSIR standard version</i>	25
Figure 12	<i>RSIR - CSIR terminal board version</i>	25
Figure 13	<i>RSIR and CSIR terminal board version</i>	26
Figure 14	<i>RSIR and RSCR terminal board version with PTC starting device</i>	26
Figure 15	<i>PSC and CSR Versions</i>	27
Figure 16	<i>CSR BOX with internal or external overload protector</i>	27
Figure 17	<i>Standard CSIR (with the relay T.I. 3CR or G.E. 3ARR2)</i>	28
Figure 18	<i>CSIR BOX (with relay T.I. 3CR or G.E. 3ARR2)</i>	28
Figure 19	<i>CSIR BOX (with relay G.E. 3ARR3 or AMF RVA)</i>	29
Figure 20	<i>Three Phase</i>	29
Figure 21	<i>Carton Package Unit</i>	34
Figure 22	<i>Wood Package Unit</i>	34
Figure 23	<i>Package Label</i>	35
Figure 25	<i>“EM” (120 compressors)</i>	36
Figure 26	<i>“EM” (100 compressors)</i>	37
Figure 27	<i>“NB” (80 compressors)</i>	37
Figure 28	<i>Components packing label</i>	38

---

---

Figure 29	<i>Single Compressor Package</i>	39
Figure 30	<i>Rubber Grommets Assembling Process</i>	70
Figure 31	<i>Rubber Grommets</i>	71
Figure 32	<i>Rotalock Valve</i>	74
Figure 33	<i>Valve Position</i>	75

## INDEX OF TABLES

Table 1	<i>Compressor Series - Application - Refrigerants</i>	13
Table 2	<i>Applications</i>	13
Table 3	<i>Electrical motor starting torque classification</i>	14
Table 4	<i>Electrical motor types</i>	14
Table 5	<i>Voltages &amp; Frequencies</i>	15
Table 6	<i>Electrical components</i>	16
Table 7	<i>Cooling Types</i>	16
Table 8	<i>Wiring Diagram</i>	23
Table 9	<i>IP Degree</i>	30
Table 10	<i>Maximum level of residual humidity</i>	31
Table 11	<i>Lubricant oils used in the compressors</i>	32
Table 12	<i>Minimum quantity of oil</i>	32
Table 13	<i>Special Version Examples</i>	33
Table 14	<i>Characteristics of carton multiple packages</i>	34
Table 15	<i>Characteristics of returnable multiple wood packages</i>	36
Table 16	<i>Load Characteristics for 20' container</i>	41
Table 17	<i>Characteristics of load by truck</i>	41
Table 18	<i>Acceptable compressor position during transportation</i>	42
Table 19	<i>Maximum height for multiple throwaway carton packages</i>	43
Table 20	<i>Maximum height for multiple returnable packages</i>	44
Table 21	<i>R134a Physical Characteristics</i>	49
Table 22	<i>R134a Ecological Characteristics</i>	49
Table 23	<i>R600a Physical characteristics</i>	52
Table 24	<i>R 600a Ecological Characteristics</i>	52
Table 25	<i>R 404A Physical Characteristics</i>	54
Table 26	<i>R 404A Ecological Characteristics</i>	54
Table 27	<i>R 407C Physical Characteristics</i>	57
Table 28	<i>R 407C Ecological Characteristics</i>	57
Table 29	<i>R290 Physical Characteristics</i>	60

---

Table 30	<i>R290 Ecological Characteristics</i>	60
Table 31	<i>Suggested Filter Dryer</i>	62
Table 32	<i>Inconvenient caused by moisture in the system</i>	62
Table 33	<i>Choice of Capillary</i>	63
Table 34	<i>Rubber Grommets</i>	71
Table 35	<i>Suggested tightening torques</i>	74
Table 36	<i>Fan Coolers Characteristics</i>	75
Table 37	<i>Maximum Refrigerant Charge</i>	76
Table 38	<i>Discharge gas maximum pressures</i>	79
Table 39	<i>Pressure limit value</i>	82
Table 40	<i>Troubleshooting and service chart</i>	84

# 1 TECHNICAL DOCUMENTS

The technical and technical-commercial documents of Aspera compressors produced by Embraco Europe are available in the following types:

## 1.1 GENERAL CATALOG

This technical-commercial catalog includes information about all gas refrigerants that are approved by Embraco Europe and organizes all compressors into different series and applications (LBP, MBP, HBP, Air Conditioning) divided by 50 Hz or 60 Hz frequency.

The information in the general catalog is as follows:

- Product information
- Gas refrigerant application guide
- General technical data
- Nominal performance and energy consumption according to “sub-cooled liquid” and EN 12900 CECOMAF test conditions (only for models with refrigerant R134a and R600a in 50Hz).
- Reference table for identifying drawings and diagrams of each compressor model.
- External view of the compressor with principal dimensions.
- Identification nameplates
- Grommets and sleeves
- Assembling process
- Wiring diagrams
- Electrical connections

## 1.2 GENERAL GUIDE OF COMPRESSORS

This technical-commercial guide represents a quick reference for choosing compressors. It includes information about all gas refrigerants that are approved by Embraco Europe and organizes all compressors into different series and applications (LBP, MBP, HBP and Air conditioner) divided by 50Hz or 60Hz frequency.

The information in the guide is as follows:

- Identification table of available Aspera voltage and frequency codes.
- Nominal performance and energy consumption according to the “sub-cooled liquid” and EN 12900 CECOMAF test conditions.

## 1.3 TECHNICAL BULLETIN

This document contains exclusive compressor technical data:

- External view of the compressor with principal dimensions
- Mechanical characteristics
- Electrical characteristics of motor and components

Doc. Code	Emission	Revision	Date	Page
MP01EH	2000-04	07	2010-02	11 - 98

- Wiring diagrams
- Graphs of “Mass Flow”, “Current Input”, “Watt Input”, “Refrigeration Capacity”, as a function of the evaporating temperature (within the characteristic field) at two or more condensing temperatures.

**1.4**

---

**ELECTRICAL COMPONENT CATALOG**

This catalog allows the identification of the electrical components to be supplied with the Compressor Model and its Bill of Lading.

The information contained in the catalog is:

- Reference of Compressor Model & Bill of Lading.
- Compressor electrical data (Voltage & frequency, motor type, nominal Watt, nominal FLA, LRA, and resistance of the electrical motor).
- Starting relay & O/L protector characteristics and code numbers used by Aspera and suppliers.
- Run & start capacitors (if applicable) characteristics and Aspera code number.
- “Terminal board assembly” or “Electrical box” Aspera code number.
- The use of electrical components different that those approved by Embraco can cause abnormal working and even severe damage to compressor.

**1.5**

---

**COMPRESSOR HANDBOOK**

The Handbook includes useful information about compressors and their components and addresses the correct application of the compressors with various refrigerants.

**1.6**

---

**ELECTRONIC CATALOG**

The Electronic Catalog is available on our web site “[www.embraco.com](http://www.embraco.com)”.

## 2 GENERAL INFORMATION

### 2.1 COMPRESSOR RANGES

Table 1 indicates the refrigerant types used in the compressors available on catalog for each series and according to the different applications.

Table 1 *Compressor Series - Application - Refrigerants*

SERIES	APPLICATION			
	LBP	MBP	HBP	AC
EM	R134a - R600a - R404A - R290	R404A - R290	R134a - R600a	–
–				
NB	R134a - R600a - R404A - R507	R404A - R507	R22 - R134a	–
NE	R22 - R134a - R404A - R507 - R290	R404A - R507 - R290	R22 - R134a - R600a	R22 - R407C
T - NT	R22 - R134a - R404A - R507 - R290	R404A - R507 - R290	R22 - R134a - R600a	R22 - R407C
NJ	R22 - R134a - R404A - R507	R404A - R507	R22 - R134a	R22 - R407C

The available models in the different applications, the thermodynamic and electrical performances, the external dimensions and the approved electrical components, are listed in the General Catalog, Technical Bulletin, Electrical Components Catalog and Electronic Catalog, which complement this Handbook.

### 2.2 APPLICATIONS

Table 2 *Applications*

TYPE	DESCRIPTION
LBP	<b>(Low Back Pressure)</b> Models at low evaporating temperatures, suitable for applications with working evaporating temperatures lower than -20 °C; for instance refrigerators, freezers, frozen food cabinets, frozen food display cases, display windows, etc.
MBP	<b>(Medium Back Pressure)</b> Models for medium evaporating temperatures, suitable for applications with working evaporating temperatures higher than -20 °C; such as fresh food cabinets, drink coolers, ice makers etc.
HBP	<b>(High Back Pressure)</b> Models at high evaporating temperatures, suitable for applications with working evaporating temperatures higher than -15 °C; such as fresh food cabinets, drink coolers, ice makers, dehumidifiers etc.
AC	<b>(Air Conditioning)</b> Models for air conditioning with R22, suitable for applications with positive working evaporating temperatures, such as air conditioners, heat pumps and dehumidifiers.

### 2.3 STARTING TORQUE CLASSIFICATION

Table 3 describes the types of starting torque for the electrical motors of Aspera and Embraco compressors produced by Embraco Europe.

Table 3 *Electrical motor starting torque classification*

TYPE	DESCRIPTION
<b>LST</b>	<b>Low Starting Torque</b> LBP - MBP - HBP - AC applications with RSIR - RSCR - PSC electric motors. Execution suitable for systems with a capillary tube or with balanced pressures at start up.
<b>HST</b>	<b>High Starting Torque</b> LBP - MBP - HBP applications with CSIR- CSR electric motors. Execution suitable for systems with expansion valve or capillary, with unbalanced pressures at start up.

### 2.4 ELECTRIC MOTOR TYPES

Table 4 describes the different types of electric motors used in Aspera compressors.

Table 4 *Electrical motor types*

TYPE	DESCRIPTION
<b>RSIR</b>	<b>Resistance Start - Inductive Run</b> This motor type, used in the compressor of small power, has a low starting torque ( <b>LST</b> ) and must be applied only to capillary tube systems where the pressures equalize. The motor is characterized by a start winding with high ohmic resistance and must be disconnected when it reaches the stabilized rotational speed. An electromagnetic relay, calibrated for the motor current, disconnects the start winding at the end of the start up. An alternative to the electromagnetic relay is, for some models, a <b>PTC</b> solid state-starting device.
<b>CSIR</b>	<b>Capacitive Start - Inductive Run</b> Similar to RSIR motor, but with a different start winding in series with a start capacitor of suitable capacitance to get a high starting torque.
<b>RSCR</b>	<b>Resistance Start - Capacitive Run</b> Similar to RSIR motor version but uses a PTC solid state starting device and a permanent connected run capacitor to improve its efficiency.
<b>PSC</b>	<b>Permanent Split Capacitor</b> PSC version with capacitive run winding. This motor is characterized by the run capacitor permanently connected in series with the start winding; both remain connected even after the motor starts. The starting torque is enough to guarantee that the compressor starts only with balanced pressures in capillary tubes systems or with a pressure equalizer.



TYPE	DESCRIPTION
CSR	<b>Capacitive Start &amp; Run</b> CSR version with capacitive run and start windings. Same as PSC motor but with a start capacitor in series with the start winding. A potential starting relay, calibrated for each motor, disconnects the start capacitor at the end of the start. The motor is characterized by a high starting torque (HST) and high efficiency.
3Ø	<b>Three phase</b> Three-phase windings with star connections.

**2.5**
**VOLTAGES & FREQUENCIES**

Table 5 are indicates the various rated voltages and frequencies with the corresponding operating ranges and minimum starting voltages of the compressors.

**PLEASE NOTE:** Not all voltages and frequencies are available on all compressors. For the availability of different voltages and frequencies for each model and refrigerant type consult the Aspera Compressor Catalog. For the different versions availability, please check with the Embraco Europe Sales & Marketing Department.

 Table 5 *Voltages & Frequencies*

ASPERA CODE	RATED VOLTAGE & FREQUENCY <sup>(1)</sup>	VOLTAGE WORKING RANGE		MINIMUM START VOLTAGE	
		@ 50 HZ	@ 60 HZ	@ 50 HZ	@ 60 HZ
A	220-240 V 50 Hz 1~	198 V ÷ 254 V		187 V	
B	200-230 V 50 Hz 1~ / (208-230 V 60 Hz 1~)	180 V ÷ 244 V	187 V ÷ 244 V	170 V	177 V
C	220 V 50 Hz 1~	200 V ÷ 242 V		187 V	
D	208-230 V 60 Hz 1~ / (200 V 50 Hz 1~)	180 V ÷ 220 V	187 V ÷ 244 V	170 V	177 V
G	115 V 60 Hz 1~ / (100 V 50 Hz 1~)	90 V ÷ 110 V	103 V ÷ 127 V	85 V	98 V
J	230 V 60 Hz 1~ / (200 V 50 Hz 1~)	180 V ÷ 220 V	207 V ÷ 253 V	170 V	195 V
K	200-220 V 50 Hz 1~ / (230 V 60 Hz 1~)	180 V ÷ 234 V	207 V ÷ 253 V	170 V	195 V
M	380-420 V 50 Hz 3~ / (440-480 V 60 Hz 3~)	332 V ÷ 445 V	396 V ÷ 509 V	323 V	374 V
N	200-240 V 50 Hz 1~ / (230 V 60 Hz 1~)	180 V ÷ 254 V	207 V ÷ 253 V	170 V	195 V
P	380 V 60 Hz 3~		342 V ÷ 418 V		323 V
Q	100 V 50/60 Hz 1~	90 V ÷ 110 V	90 V ÷ 110 V	85 V	85 V
R	200 V 50/60 Hz 3~	180 V ÷ 220 V	180 V ÷ 220 V	170 V	170 V
T	220-230 V 50 Hz 1~	198 V ÷ 244 V		187 V	
U	220 V 60 Hz 1~		200 V ÷ 242 V		187 V
V	230 V 50 Hz 1~	207 V ÷ 253 V		195 V	
W	220 V 50/60 Hz ~	200 V ÷ 242 V	200 V ÷ 242 V	187 V	187 V

(1) Voltage/Frequency range indicated in brackets may not be included in Agency Approvals.

## 2.6 COMPRESSOR ELECTRICAL COMPONENTS

The intended electrical components for each type of electric motor are indicated in Table 6 and are usually supplied as compressor equipment.

Only under some circumstances agreed on with the customer, can the electrical components be excluded from the compressor equipment.

Table 6 *Electrical components*

MOTOR TYPE	OVERLOAD PROTECTOR	STARTING DEVICE			CAPACITORS	
		CURRENT RELAYS	VOLTAGE RELAYS	PTC	START	RUN
RSIR	YES	YES <sup>(1)</sup>		YES <sup>(1)</sup>		
CSIR	YES	YES			YES	
RSCR	YES			YES		YES
PSC	YES					YES
CSR	YES		YES		YES	YES
3Ø	YES					

(1) For some RSIR models in the NB series, a PTC starting device can be used as an alternative to the current relay. For the RSIR compressors in the BP and EM series, the PTC starting device is standard. Only some specific HBP models in the BP series can use a current relay.

## 2.7 COMPRESSOR COOLING TYPES

Table 7 lists the various cooling types intended for each compressor model, as indicated in the **Compressor Catalog** and **Technical Bulletin**.

**For information on the proper installation and cooling of the compressor, consult section 6.10 - COMPRESSOR COOLING.**

Table 7 *Cooling Types*

TYPE	DESCRIPTION
S	<b>Static cooling:</b> the compressor does not require forced cooling, but it must be installed so that the ambient air can adequately cool to avoid overheating.
F	<b>Fan cooling:</b> the compressor requires forced cooling through the use of a fan, sized as indicated in section 6.10 “Compressor Cooling”.
OC	<b>With oil cooler:</b> coil positioned in the lower internal part of the housing, immersed in the lubrication oil, where the gas coming from the first part of the heat exchanger circuit circulates.

**2.8 COMPRESSOR NAMEPLATES - IDENTIFICATION DATA**

Legend 1 **Identification data in the nameplates:**

1	Compressor Model (see Figure 6a)	8	Refrigerant
2	Bill of Materials (see Figure 7)	9	Agency Approvals
3	Supply Voltage	10	Control Digits
4	Current Consumption (when applicable)	11	Lubricant Type and Quantity
5	Locked Rotor Current (when applicable)	12	Manufacturing Date (d.m.y) or Date Code
6	Serial Number	13	Manufacturing Country (Italy, Slovakia)
7	Manufacturing Data Code (see Figure 8)		

Figure 1 **Metallic Nameplates (used up to 2001)**

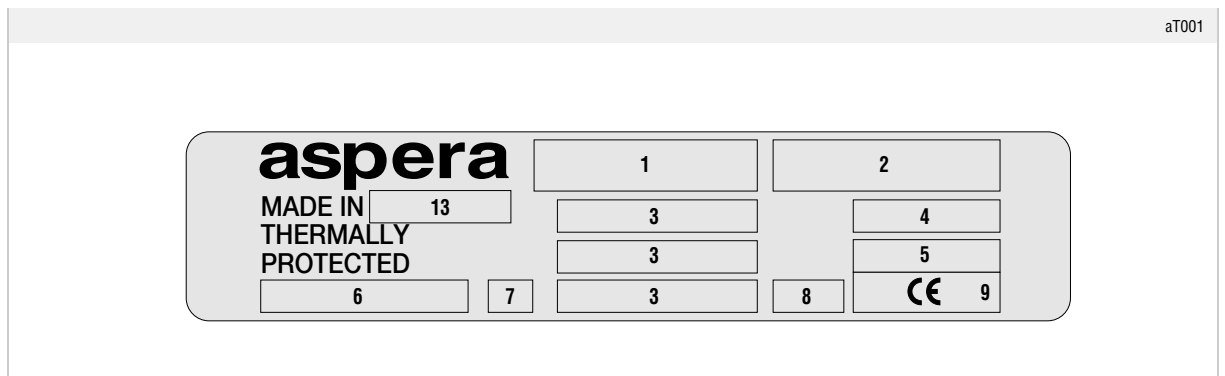

Figure 2 **Adhesive Nameplates**

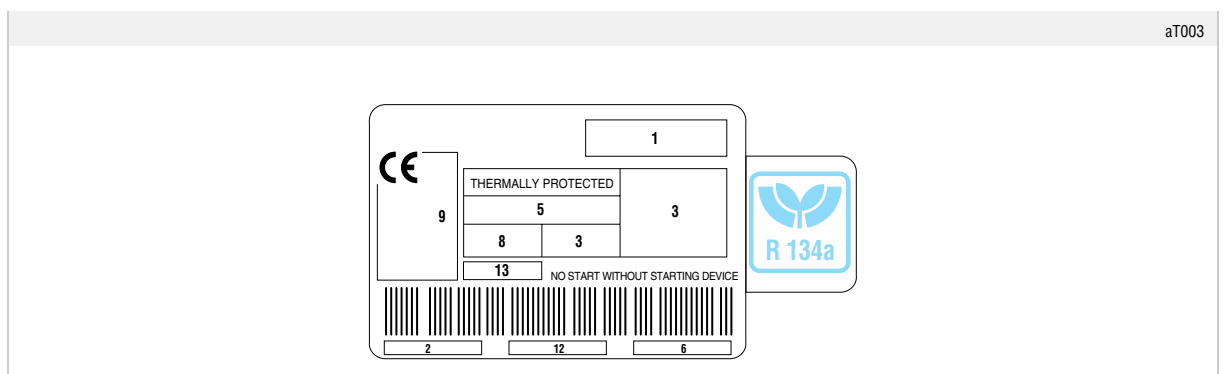

Figure 3 *Series NB/NE - Adhesive Nameplates (used up to 2003)*

Suction arrow on right side

aT005

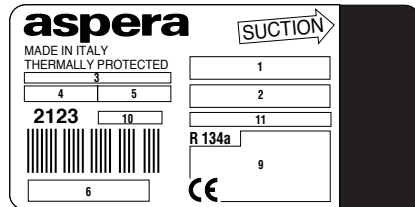

Figure 4 *Series BP - Adhesive Nameplates (used up to 2004)*

aT009

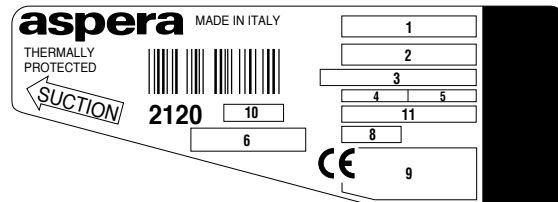

Figure 5 *Series EM - Adhesive Nameplates*

aT019

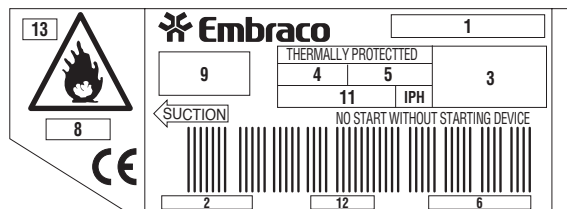

Figure 6a *Compressor Model Identification Code*

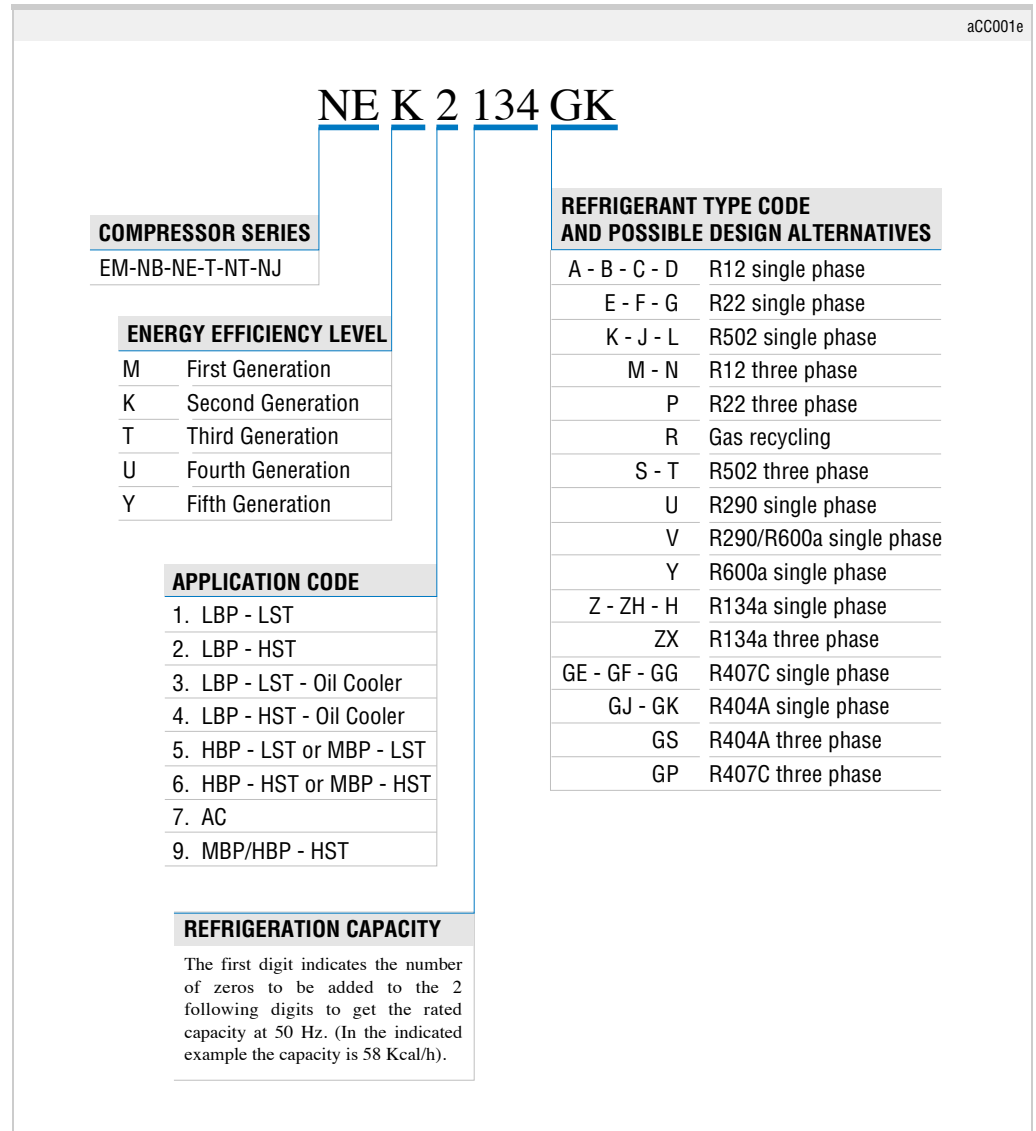

Figure 6b *Series EM - Compressor Model Identification Code*

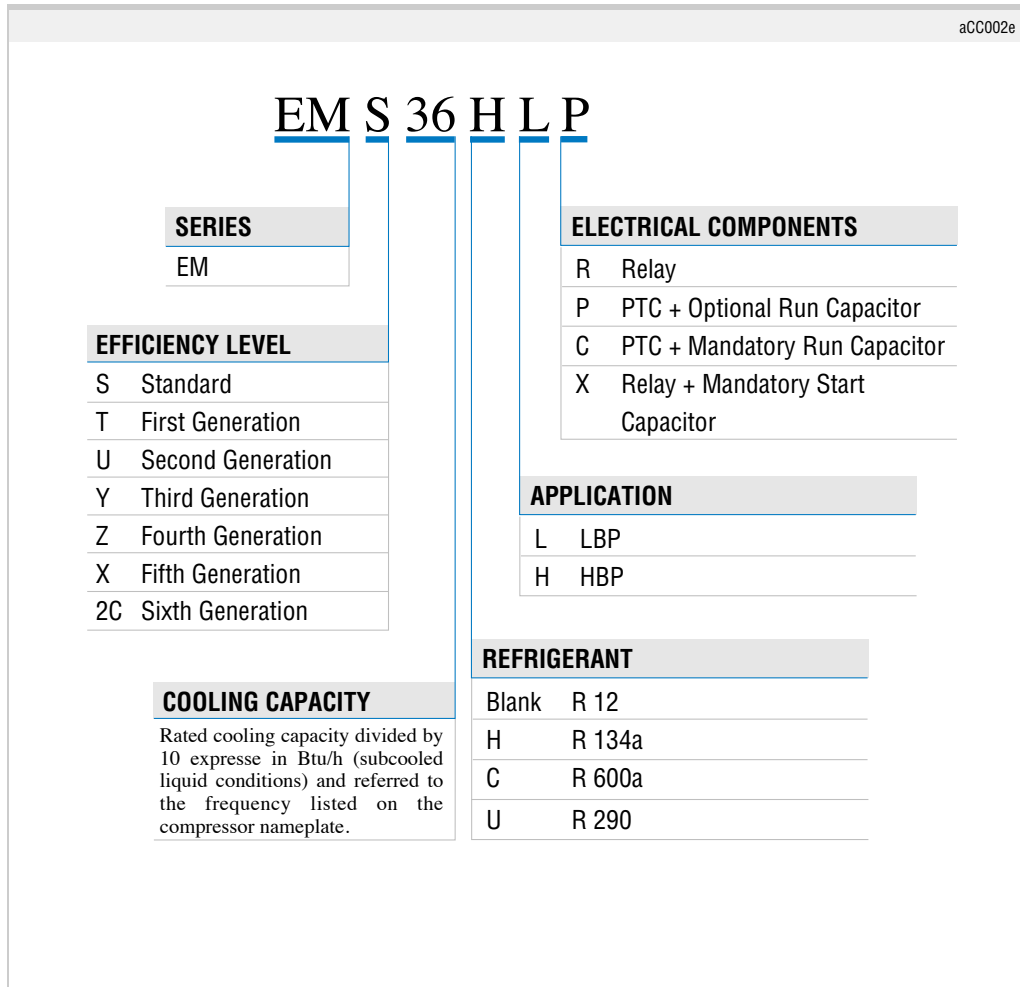

Figure 7 *Compressor Bill of Materials Code*

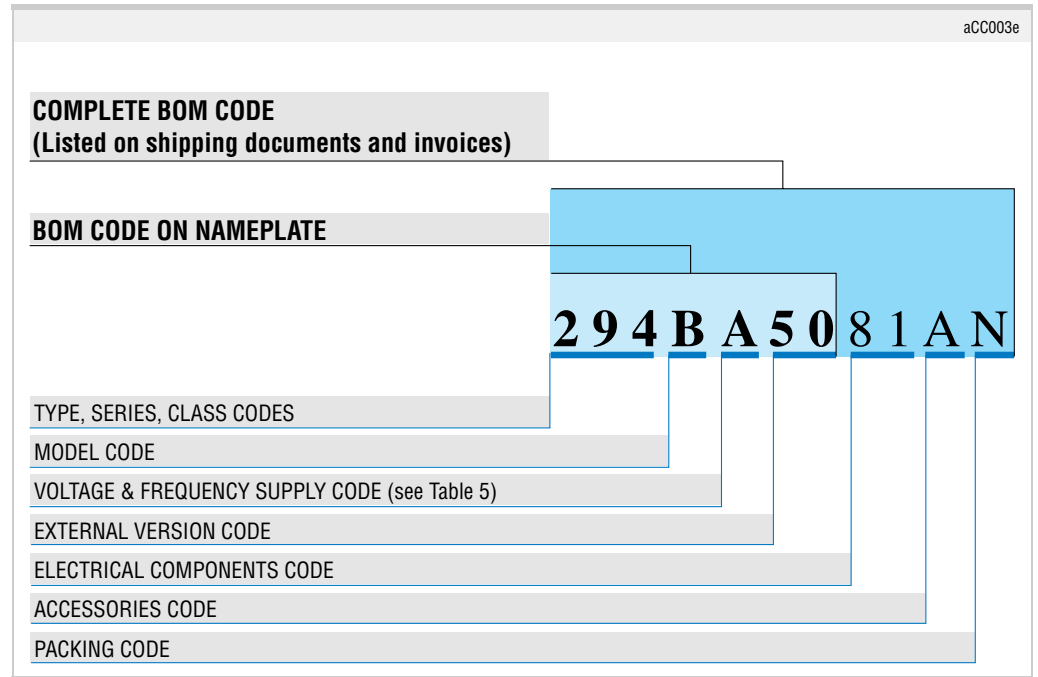

Figure 8 *Manufacturing Date Code*

aCC004e

**A B**

MONTH	YEAR FROM SEPTEMBER TO AUGUST OF FOLLOWING YEAR
<b>A</b> = SEPTEMBER	<b>B</b> = 1990 / 91
<b>B</b> = OCTOBER	<b>C</b> = 1991 / 92
<b>C</b> = NOVEMBER	<b>D</b> = 1992 / 93
<b>D</b> = DECEMBER	<b>E</b> = 1993 / 94
<b>E</b> = JANUARY	<b>F</b> = 1994 / 95
<b>F</b> = FEBRUARY	<b>G</b> = 1995 / 96
<b>G</b> = MARCH	<b>H</b> = 1996 / 97
<b>H</b> = APRIL	<b>J</b> = 1997 / 98
<b>J</b> = MAY	<b>K</b> = 1998 / 99
<b>K</b> = JUNE	<b>L</b> = 1999 / 2000
<b>L</b> = JULY	<b>M</b> = 2000 / 2001
<b>M</b> = AUGUST	<b>N</b> = 2001 / 2002
	<b>P</b> = 2002 / 2003
	<b>R</b> = 2003 / 2004
	<b>S</b> = 2004 / 2005
	<b>T</b> = 2005 / 2006
	<b>U</b> = 2006 / 2007
	<b>V</b> = 2007 / 2008
	<b>W</b> = 2008 / 2009
	<b>X</b> = 2009 / 2010
	<b>Y</b> = 2010 / 2011
	<b>Z</b> = 2011 / 2012
	<b>A</b> = 2012 / 2013

**2.9 WIRING DIAGRAMS**

The following pages represent the electrical connections wiring diagrams for all the configurations supplied with the compressors. On the wiring diagram, outlined with bold lines are the connections already existing on the electrical components (as supplied to the customer). Dotted lines represent the main connections which must be made by the customer. These include the thermostat, the supply line and the fan motor, if applicable.

The connection screws on overload protectors, relays, terminal boxes and ground plates, are supplied with a clamping torque of  $(0.1 \div 0.3 \text{ Nm}) (1 \div 3 \text{ kgcm})$ . For the final tightening during the wiring done by the customer, we suggest to apply a torque of  $0.8 \div 1.4 \text{ Nm} (8 \div 14 \text{ kgcm})$  to the screws. The final clamping torque of electrical connections screw terminals should conform to the IEC 685-2-2 standard.

Legend 2 **Wiring Diagram**

	Overload Protector		Integrated PTC Device
	Overload Protector		Current Start Relay with Capacitor Connections
	Current Start Relay		3ARR3 Start Relay
	3CR Current Start Relay		
	PTC Start Device		
	Run Capacitor		Run Capacitor (mandatory - not supplied)
	Optional Run Capacitor		Start Capacitor
	Fan		
	Lamp		Pushbutton
	3-Phase Motor		Single Phase Motor
	Low-High Pressure Switch		Thermostat
	Earth Connection		
	3-Phase Supply		Pilot Circuit 24 or 220 V
	Single Phase Supply		
	Common		Common (Internal Overload Protector)
	Run		Start
	Terminal Block		
<b>Wh</b>	White Cable	<b>Br</b>	Brown Cable
<b>Bl</b>	Blue Cable	<b>Bk</b>	Black Cable
<b>YG</b>	Yellow-Green Cable	<b>Re</b>	Red Cable
	Connections supplied		Connections to be made by the Customer (not supplied)



Table 8 **Wiring Diagram**

The represented electrical wiring diagrams are listed on the following table:

<b>SERIES</b>	<b>MOTOR TYPE</b>	<b>ELECTRICAL COMPONENTS EXECUTION</b>	<b>FIG.</b>
<b>EM</b>	RSIR	Faston terminal board (PTC starting device and overload protector)	9
<b>NB</b>	RSIR	Standard (integrated PTC starting device and overload protector)	10
	RSCR	Standard (integrated PTC starting device, overload protector and run capacitor)	
<b>T</b>	RSIR	Standard (current relay and overload protector)	11
	CSIR	Standard (current relay and overload protector and start capacitor)	
<b>NB-NE</b>	RSIR	Cord anchorage (current relay and overload protector)	11
	CSIR	Cord anchorage (current relay and overload protector and start capacitor)	
<b>T</b>	RSIR	Terminal board (current relay and overload protector)	12
	CSIR	Terminal board (current relay and overload protector and start capacitor)	
<b>NB-NE-NT</b>	RSIR	Terminal board (current relay and overload protector)	13
	CSIR	Terminal board (current relay and overload protector and start capacitor)	
<b>NB</b>	RSIR Ptc	Terminal board (PTC and overload protector)	14
	RSCR Ptc	Terminal board (PTC, overload protector and run capacitor)	
<b>T-NJ-NT</b>	PSC	Standard (external overload protector and run capacitor)	15
	CSR	Standard (3ARR3/RVA relay, external overload protector, run/start capacitor)	
<b>T-NJ-NT</b>	CSR Box	Box (3ARR3/RVA relay, internal overload protector, run/start capacitor)	16
	CSR Box	Box (3ARR3/RVA relay, external overload protector, run/start capacitor)	
<b>T-NJ</b>	CSIR	Standard (3CR/3ARR2 current relay, overload protector and start capacitor)	17
	CSIR	Standard (3CR/3ARR2 current relay, overload protector and start capacitor)	
<b>T-NJ-NT</b>	CSIR Box	Box (3CR/3ARR2 current relay, overload protector and start capacitor)	18
	CSIR Box	Box (3CR/3ARR2 current relay, overload protector and start capacitor)	
<b>NJ</b>	CSIR Box	Box (3ARR3/RVA relay, external relay and start relay)	19
	3 PHASE	Standard (internal overload protector)	20

**2.9.1 Compressor Wiring Diagram - EM Series - RSIR**

The electrical connections on the terminal board can be made with 4.76mm (3/16") male quick-connect terminations and with M 3.5 x 6 screws that are on three terminals L1-N-ground. Connection for the compressor ground is with a 4.76 mm quick-connect termination.

Figure 9 **RSIR Version terminal board with PTC starting device**

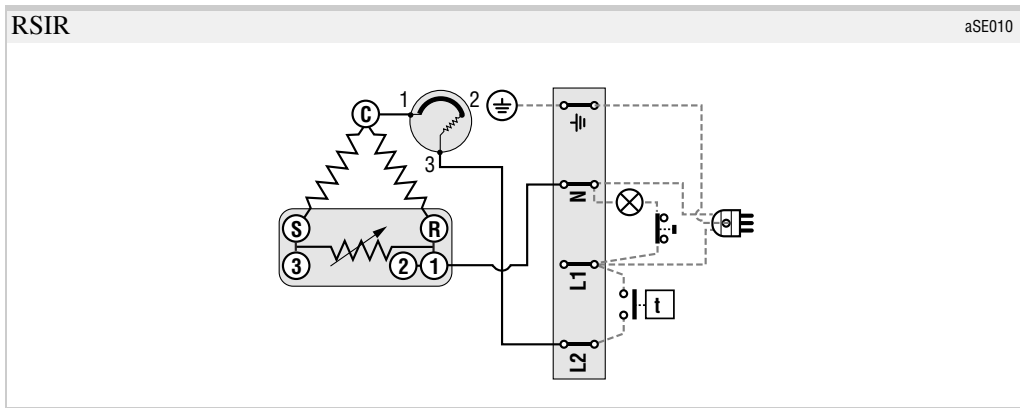

**2.9.2 Compressor Wiring Diagram NB Series – RSIR-RSCR**

Standard version allows electrical connection with 4.76mm (3/16") male quick-connect terminations to the overload protector, PTC and grounding terminal; with M 3.5 screws on the terminal for the starting device and for the compressor ground.

Figure 10 **RSIR and RSCR Standard Version**

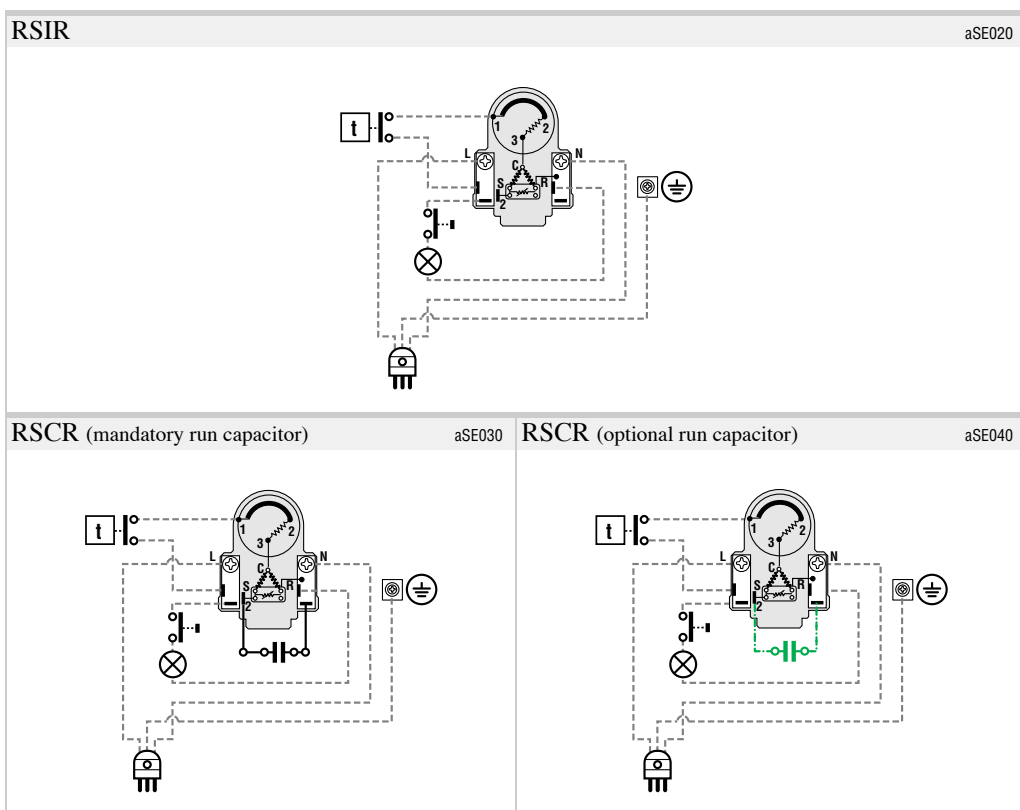

**2.9.3 Compressor Wiring Diagram T-NB-NE-NT Series (electrical components without terminal board) – RSIR-CSIR**

The basic version allows electrical connection with 4mm eyelets to the overload protector, start relay and compressor ground.

Figure 11 **RSIR and CSIR standard version**

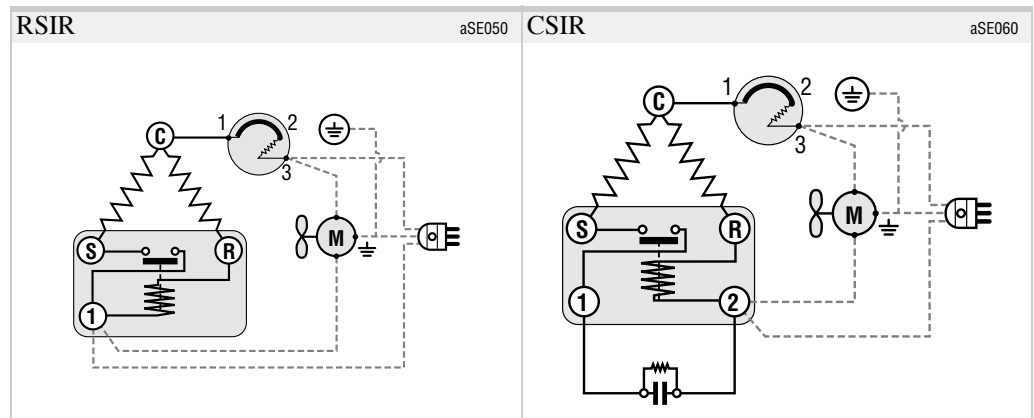

**2.9.4 Compressor Wiring Diagram T Series (electrical component with terminal board) – RSIR-CSIR**

Allows electrical connection on the terminal board available in two versions:

1. Terminal board with screw connections and a 4mm eyelet ground connection.
2. 4.76mm (3/16") male quick-connect terminations and M 3.5 screws for each terminal, 4mm eyelet for ground.

Figure 12 **RSIR - CSIR terminal board version**

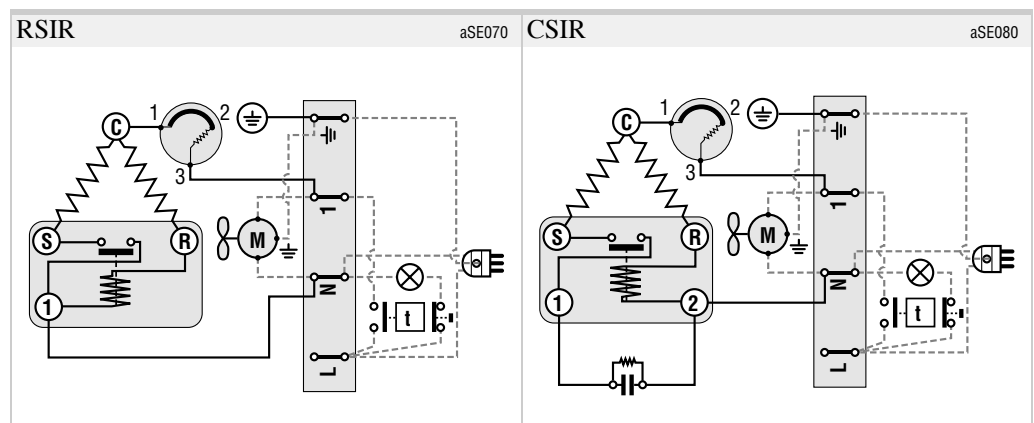

**2.9.5 Compressor Wiring Diagram NB-NE-NT Series** (electrical component with terminal board) – **RSIR-CSIR**

Allows for electrical connections on the terminal board with 4.76mm (3/16") or 6.35mm (1/4") quick-connect terminations and M 3.5 screws for terminal L - N - ground.

Figure 13 *RSIR and CSIR terminal board version*

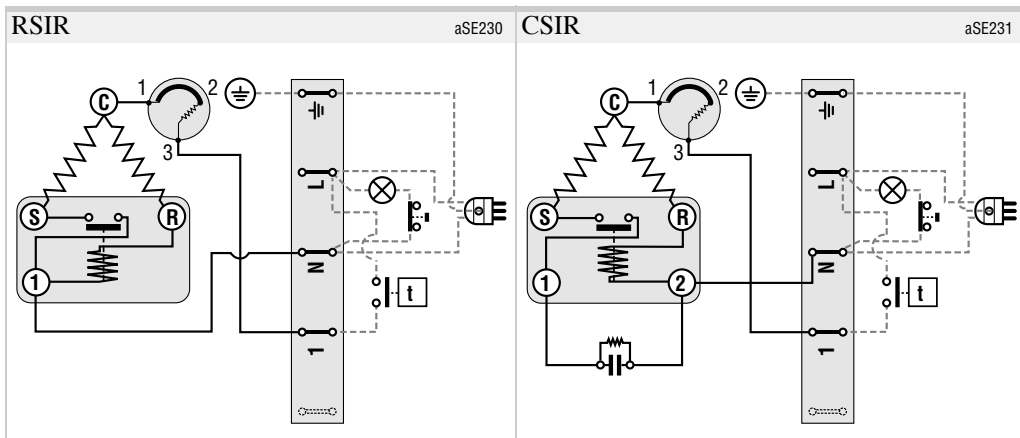

**2.9.6 Compressor Wiring Diagram NB Series** (electrical component with terminal board) – **RSIR-RSCR**

Allows electrical connections to the terminal board with 4.76mm (3/16) quick-connect terminations and M3.5 screws for terminals L-N-ground.

Figure 14 *RSIR and RSCR terminal board version with PTC starting device*

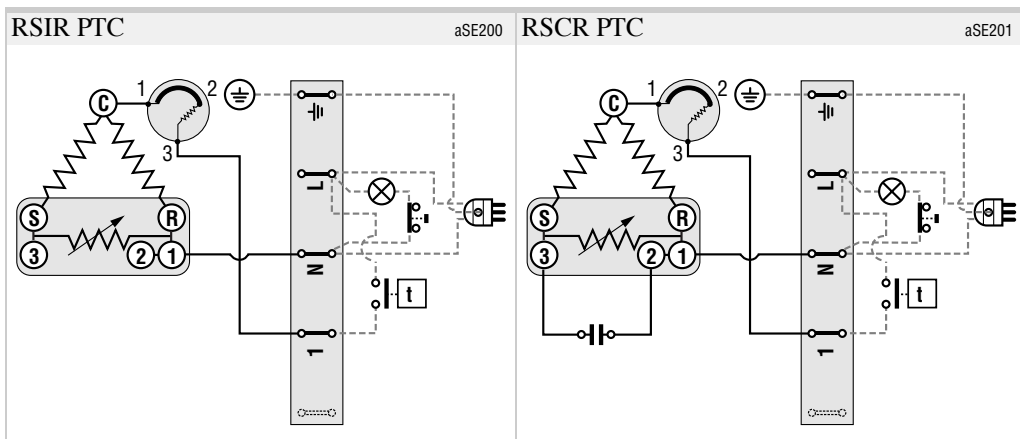

**2.9.7 Compressor Wiring Diagram T-NT-NJ Series – PSC-CSR**

Electrical connection can be made with 6.35mm (1/4") male quick-connect terminations to the hermetic terminal and capacitors. For the screws to the relay, overload protector and ground use 4mm eyelets.

Figure 15 *PSC and CSR Versions*

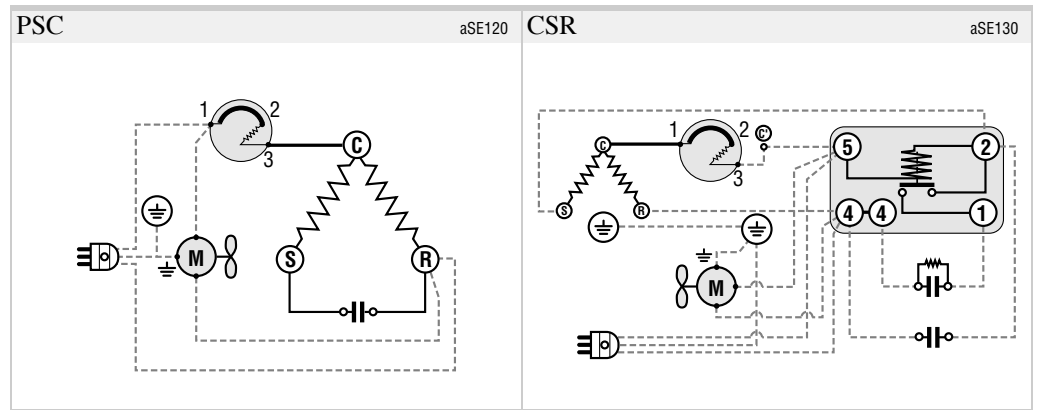

**2.9.8 Compressor Wiring Diagram NE-T-NT-NJ Series – CSR BOX**

Electrical connections can be made with 4mm eyelet terminals for the screws on the start relay and on the ground screw of the box and the compressor.

Figure 16 *CSR BOX with internal or external overload protector*

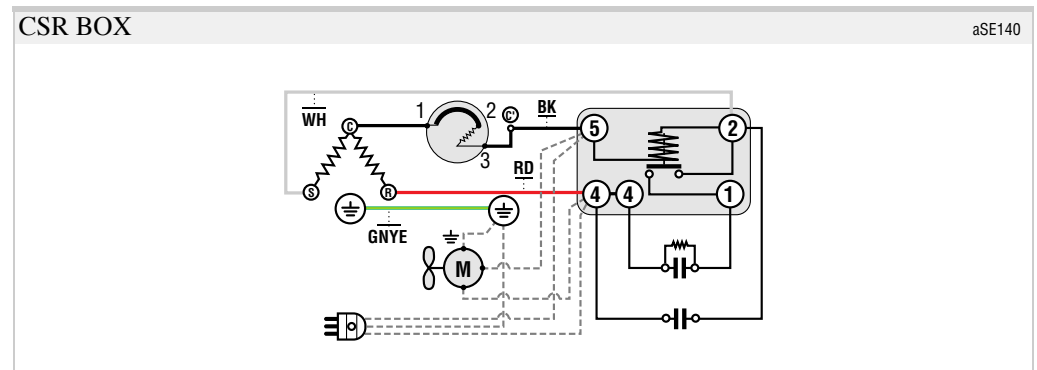

**2.9.9 Compressor Wiring Diagram T-NT-NJ Series – CSIR**

Electrical connections can be made with 6.35mm (1/4") male quick-connect terminations to the relay, start capacitor and hermetic terminals 4mm eyelet connections for the protector and ground.

Figure 17 *Standard CSIR (with the relay T.I. 3CR or G.E. 3ARR2)*

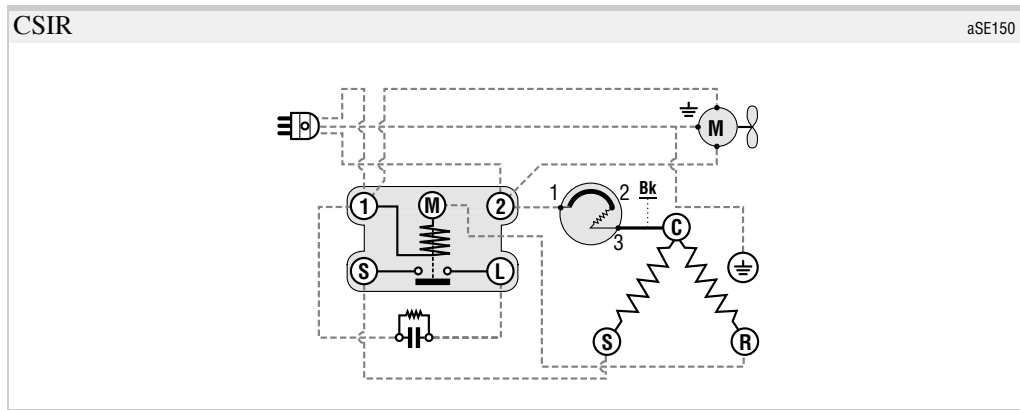

**2.9.10 Compressor Wiring Diagram T-NT-NJ Series – CSIR BOX**

Electrical connections can be made with 6.35mm (1/4") male quick-connect terminations to the relay, start capacitor and hermetic terminals 4mm eyelet connections for the protector and ground.

Figure 18 *CSIR BOX (with relay T.I. 3CR or G.E. 3ARR2)*

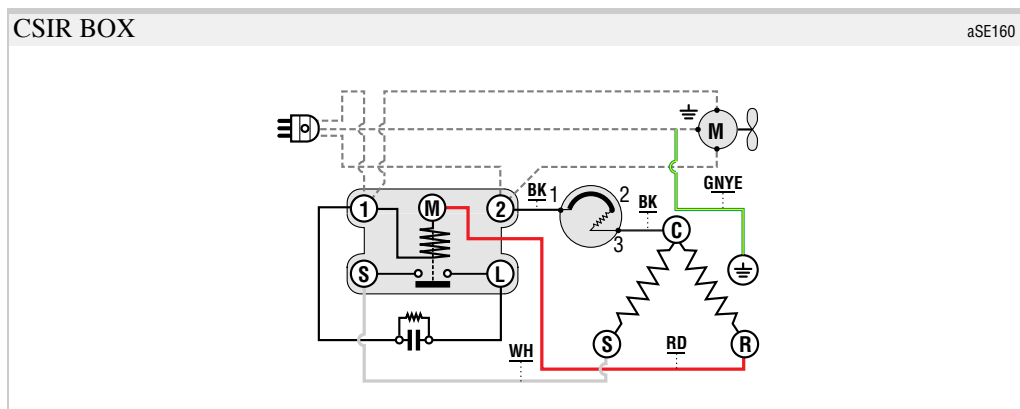

**2.9.11 Compressor Wiring Diagram NJ Series – CSIR BOX**

Electrical connections can be made with 4mm eyelet terminals for the screws on the start relay and on the ground screw of the box and the compressor.

Figure 19 **CSIR BOX (with relay G.E. 3ARR3 or AMF RVA)**

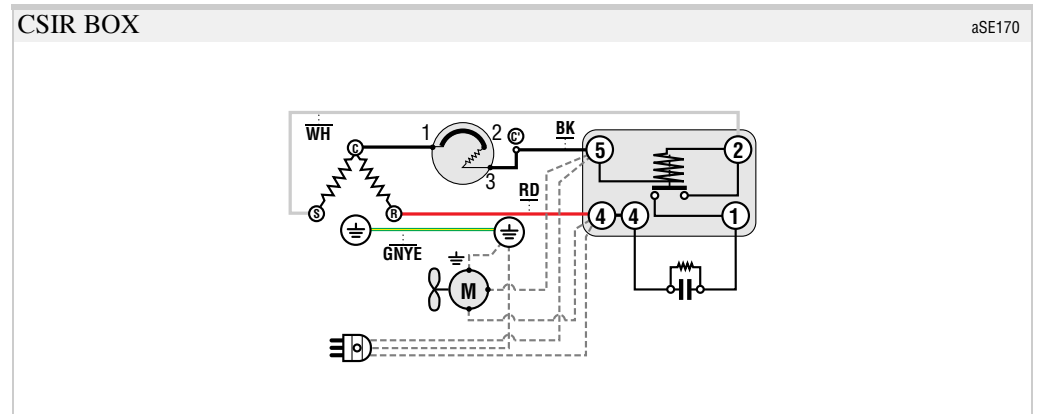

**2.9.12 THREE PHASE**

Electrical connections can be made with 6.35mm (1/4") male quick-connect terminations to the hermetic terminal and 4mm eyelet for ground connection.

Figure 20 **Three Phase**

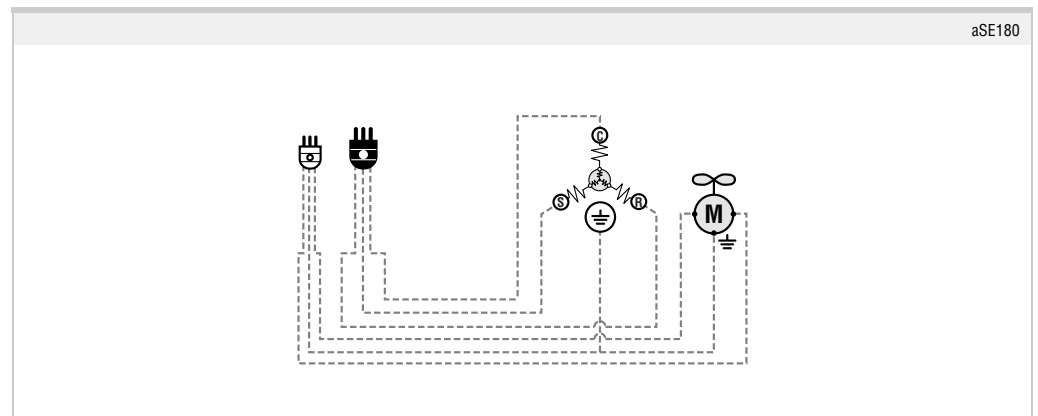

3

## COMPRESSOR SUPPLY CONDITIONS

3.1

### ELECTRICAL INSULATION

All compressors are tested with high voltage to verify the electrical insulation to ground, the dielectric strength, and in accordance with the acceptable limits of the most severe requirements from the following standards:

- CENELEC HD 277.S1 + HD 251.S3
- IEC 335-2-34 + 335-1
- VDE 0700 Teil 1 + Teil 34
- BS 3456 - Par.3 - Sect.3-18
- EN 60335-2-34 - EN 60335-1
- UL 984

3.2

### “IP” DEGREE OF PROTECTION

The degree of protection of the electrical components supplied with the compressor are listed in Table 9 in accordance with the following standards:

- IEC 529
- EN 60529

Table 9 *IP Degree*

SERIES	T	NB – NE – NT – EM	NE (AC) – T (AC) NT (AC) – NJ
“IP” DEGREE	IP 31	IP 32	IP 33

3.3

### THE COMPRESSOR SHELL HYDROSTATIC STRENGTH

The compressor shell resists pressures above those prescribed in the following standards:

- IEC 335-2-34
- EN 60335-2-34
- UL 984



### 3.4 DEHYDRATION

Table 10 *Maximum level of residual humidity*

SERIES	RESIDUAL MOISTURE MAXIMUM AMOUNT
EM - NB - NE	60 mg H <sub>2</sub> O
T - NT	80 mg H <sub>2</sub> O
NJ	90 mg H <sub>2</sub> O

### 3.5 PAINTING

Black water based paint resists corrosion for 240 hours (test in humid atmosphere - ambient 43 °C and relative humidity 100% - according to standard ASTM D 2247).

The compressors are supplied with the tube ends and the electrical connections on the unpainted hermetic terminal.

### 3.6 COMPRESSOR PRESSURISATION

The compressor is pressurized to a pressure of about 0.2 bar with dry air (dew point lower than -40 °C); the tubes are sealed with rubber plugs to maintain this pressure.

The compressors for use with hydrocarbons are supplied without pressurization.

### 3.7 OIL CHARGE

Table 11 shows the lubricant charged in the various series of compressors. The quantity is indicated in the General Catalog and Technical Bulletin. Only in an exceptional case, in accordance with the Sales Department, can the compressors be shipped without oil.

In the interest of warranty, occasionally additives or substitution of the lubricant, can be made by the customer under the approval of Embraco Europe.

A colored "O" stamped on the compressor cover indicates the presence and type of oil (for color and oil type see Table 11).

The maximum humidity content in the oil is 40 ppm.

Table 11 *Lubricant oils used in the compressors*

SERIES	Brand	Type	Viscosity	STAMP <sup>(1)</sup>
R22 models <sup>(4)</sup>	Reniso 46	Alkilbenzene	ISO 46	Blue
R22 AC models	Avilube FC 32	Mineral	ISO 32	White
R134a, R404A, R407C, R290 <sup>(2)</sup>	Emkarate RL 22HB	Polyolester	ISO 22	Yellow
R134a NBT	Emkarate RL 10H	Polyolester	ISO 10	Violet
R134a, R404A, R290 EMT	Emkarate RL 22H	Polyolester	ISO 22	(3)
R600a NBM	Avia FCA 15EP	Mineral	ISO 15	Pink
R600a NBT, NBU, NBY	Avia FCA 7EP	Mineral	ISO 7	Red
R600a EMT, EMU, EMY, EMZ, EMX	Microlab	Alkilbenzene	ISO 5	(3)

(1) Color of the "O" stamped on compressor cover  
 (2) Except EMT and NBT  
 (3) On EM compressors no stamp, but oil type is printed in clear onto cover  
 (4) Except R22 AC models

### 3.8

#### MINIMUM QUANTITY OF LUBRICANT

The minimum amount of oil in the compressor that guarantees the correct lubrication is indicated in Table 12:

 Table 12 *Minimum quantity of oil*

SERIES	EM	NB	NE	T - NT	NJ
OIL cm <sup>3</sup> min.	130	150	200	300	500

Oil quantities below the minimum prescribed level will not allow the oil pump to prime and will cause wear, leading to the eventual seizure of the mechanical parts.

**3.9**

**SPECIAL VERSIONS**

All special version compressors that are indicated in the catalog or that are a customer's special request, may not be available; Table 16 shows all special versions intended for each compressor series. For the availability of the versions in the table or the feasibility of others not mentioned, please contact the Embraco Europe Sales Department.

Table 13 *Special Version Examples*

<b>SERIES</b>	<b>DESCRIPTION</b>
<b>EM</b>	Compressors with a clip on the cover for the mounting of a condensate pan.
<b>NB – NE</b>	Compressors with Universal base plate (4 holes with a diameter of 19.05mm with dimensions of 101.6 x 165 mm) and internal standard tube ID.
<b>NJ</b>	Compressors without suction tubes but with a fixture for rotalock valve (not supplied).
<b>NJ</b>	Compressors without suction tubes but with a fixture for rotalock valve supplied with associated parts (unassembled).
<b>All Series</b>	Compressors without grommets and sleeves.

## 4 COMPRESSOR PACKAGING

### 4.1 MULTIPLE CARTON AND WOOD DISPOSABLE PACKAGE

This type of package consists of cartons containing one or more levels of compressors in the quantities indicated in Table 14, secured with straps on wooden pallet skids with dimensions of 830 mm x 1130 mm and a variable height according to the compressor model. For overseas shipments or in the case of difficult transport, plywood protection is available for the standard packaging with the sides and cover secured with straps.

Table 14 *Characteristics of carton multiple packages*

SERIES	PACKAGE UNIT	Fig.
EM	80, 100, 120	Figure 22
NB – NE	40, 80	Figure 22
NB – NE electricals assembled	37, 74	Figure 22
T	40, 60	Figure 22
T electricals assembled	30	Figure 22
NT	36	Figure 22
NT electricals assembled	24	Figure 21
NJ	36	Figure 21

Figure 21 *Carton Package Unit*

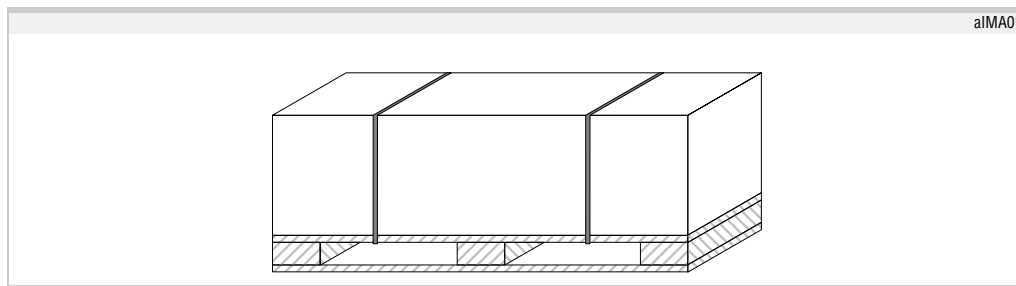
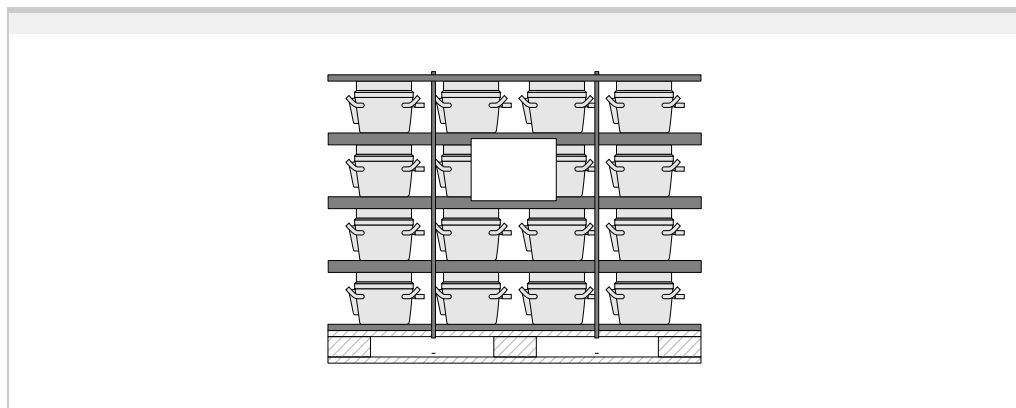

Figure 22 *Wood Package Unit*



#### 4.1.1 Compressor Identification Marks

Tags are applied on two sides of each package and report the following data:

Figure 23 *Package Label*



1. Compressor Bill of Material
2. Compressor Bill of Material (Type 39 bar code)
3. Compressor Model
4. Voltage & Frequency
5. Refrigerant
6. Package Quantity
7. Package Serial Number (Type 128 bar code)
8. Package Serial Number

**4.2 RETURNABLE WOOD PACKAGE**

This type of package consists of a shipping skid of 790 mm x 1200 mm on which are positioned the elements composing the packaging of various compressor layers, as listed below, secured with straps to the shipping skid (see figures 25-26-27).

Legend 4

A	SHIPPING SKID	on which the base is positioned.
B	BASE	on which the first layer of compressors is positioned.
C	SEPARATOR SKID	are positioned between layers, in quantities according to the compressor series, as indicated in Table 15.
D	TOP SKID	upper element closing of the package.

This type of package, created to comply to recycling regulations, requires returning to Aspera of all components for their reuse.

Furthermore they should arrive arranged in reverse sequence (top skid, separator skid, base, shipping skid) or in separated groups (all shipping skids, all bases, all separator skids and all top skids).

Table 15 *Characteristics of returnable multiple wood packages*

SERIES	PACKAGING TYPE
EM	120 compressors per package (6 layers of 20 compressors) Figure 25
	100 compressors per package (5 layers of 20 compressors) Figure 26
NB	80 compressors per package (4 layers of 20 compressors) Figure 27

Figure 25 *“EM” (120 compressors)*

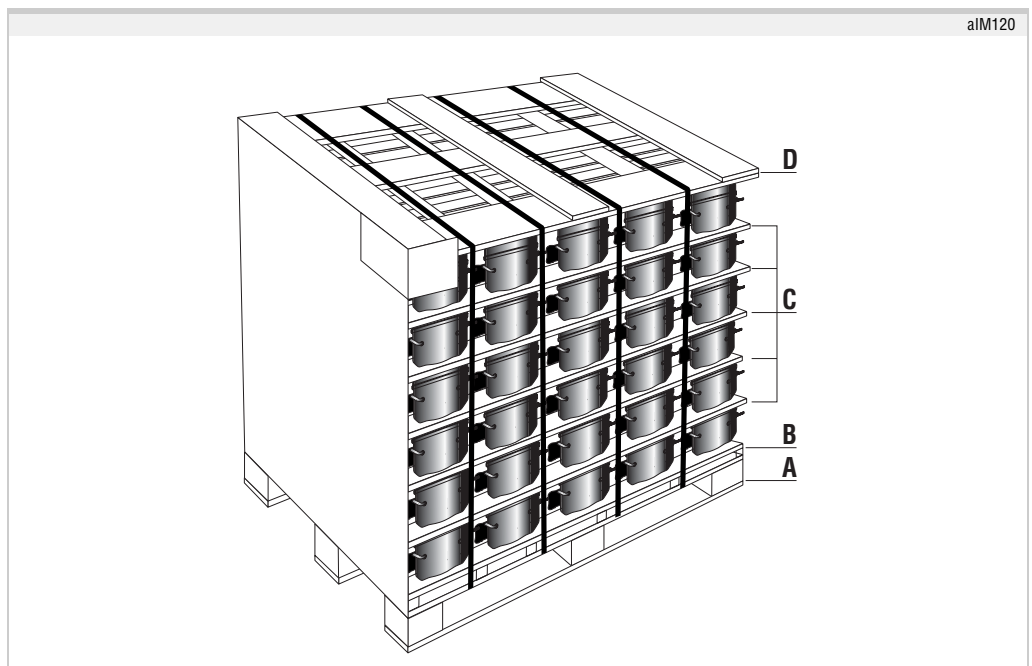

Figure 26 *“EM” (100 compressors)*

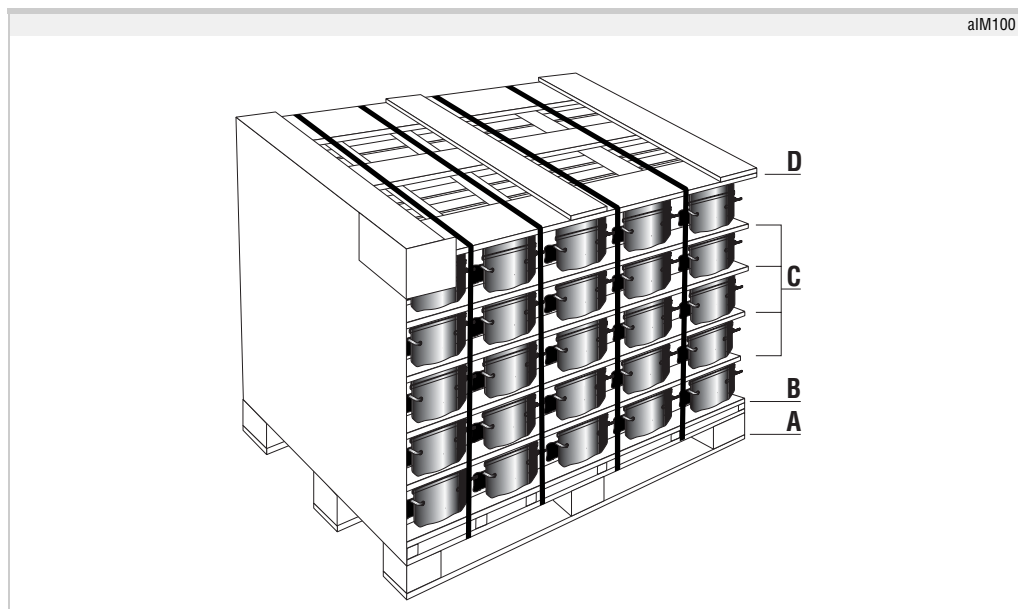
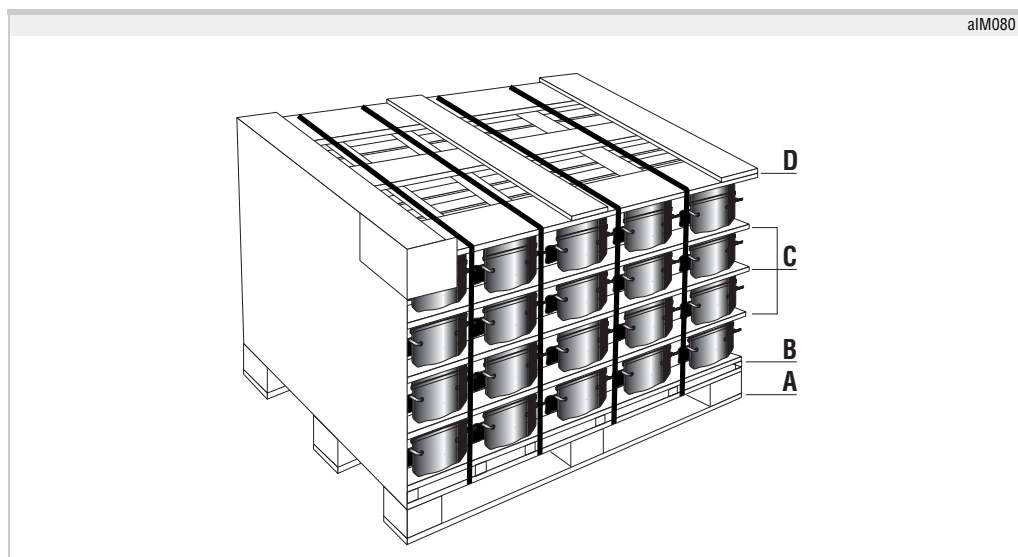

Figure 27 *“EM - NB” (80 compressors)*



#### 4.2.1 Compressor identification marks

Two tags placed on the outer side of the package indicate the data of the contents (see 4.1.1).

**4.3 PACKAGE FOR ELECTRICAL COMPONENTS AND ACCESSORIES**

Electrical components and accessories are packed separately in carton boxes. A label is applied showing the following data:

Legend 5 **Components packing label**

1. Compressor Bill of Materials (complete of electrical components and accessories)
2. Compressor Type
3. Required Quantity
4. Customer Name
5. List of electrical components and accessories shipped (code / description / quantity)

Figure 28 **Components packing label**

AIM008										
 <b>Embraco</b> EUROPE S.r.l. STABILIMENTO		<b>BUONO DI PRELIEVO</b> <b>COMPONENTI ELETTRICI E ACCESSORI</b>				<b>DOCUMENTO</b> NUMERO      DATA				
COD. DISTINTA BASE <b>1</b>		DESCRIZIONE MODELLO <b>2</b>		Q.T., RICH. <b>3</b>	CLIENTE <b>4</b>		CAUSALE	DESTINAZIONE		
MAG.	COD. DISEGNO	DESCRIZIONE				U.M.	Q.T., RICH.	Q.T., CONS.	Q.T., MANC.	
<div style="position: relative; width: 100%; height: 100%;"> <span style="position: absolute; top: 50%; left: 50%; transform: translate(-50%, -50%); font-size: 2em;">5</span> </div>										
ENTE EMITTENTE		FIRMA RESPONSAB.		DATA EMISSIONE		ENTE RICEVENTE		FIRMA RESPONSAB.		VISTO



**4.4 SINGLE PACKAGE**

This type of package consists of a carton and an internal separator to prevent any compressor movement.

The electric equipment is assembled on compressor, while rubber grommets and sleeves are supplied unassembled, in a polyethylene bag.

The CSR-CSIR models in the version with Box have some electric equipment assembled on compressor (cover and ground screw; protector spring and overload protector when required), while the rubber grommets and the sleeves are in a polyethylene bag.

The assembled Box (relay, capacitors, and connecting cables) is supplied in a separate package.

A new package with all components inside, included the Box, is now available.

Figure 29 *Single Compressor Package*

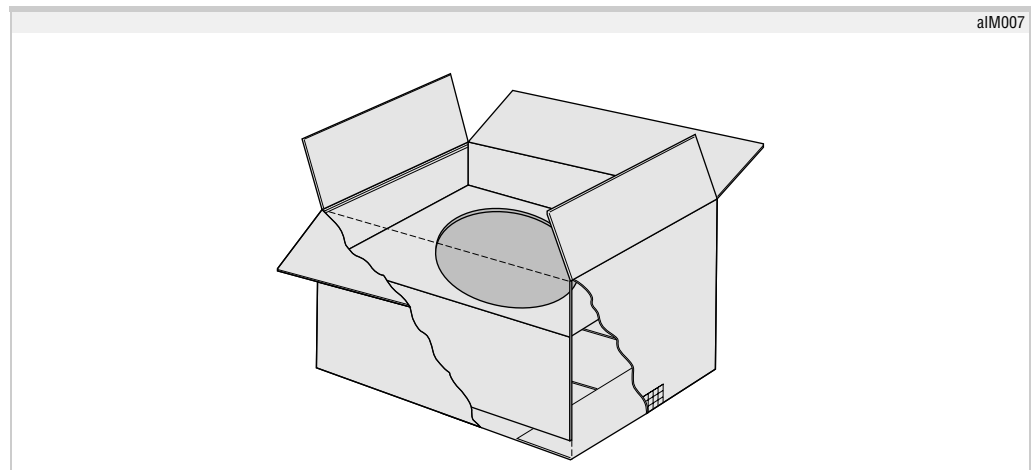

alm007

## 5 HANDLING, TRANSPORTING AND STORING COMPRESSORS

### 5.1 HANDLING

The handling of the multiple packages must be done only by forks via “Transpallet” and “Lift Trucks”. Access is available from all four sides of the package. It is suggested that the use of forks having a length no longer than the size of the pallet’s shortest side (830mm for throwaway cartons or 790mm for wooden recycling packages), to avoid damaging the next packages and the compressors inside with the forks protruding from the back side of the pallet.

**ATTENTION:** The multiple packages must not be handled with cranes by means of cables and hooks. Embraco Europe will not be responsible for damages to the product resulting from the use of improper handling.

### 5.2 TRANSPORTING

The transportation of all types of packaging must be made with an upright compressor (working position), as indicated by the vertical arrow placed on the sides of the carton.

Follow these instructions, particularly for the “Single packages”, which are easier to damage.

Incorrect transport can cause deformation of brackets and internal mufflers and/or oil entering into the suction mufflers and stator shifts, which can result in a reduction of stator/rotor air gap.

The consequences during operation can appear with deformations or breaks of reed valves and springs, and with starting problems of the electric motor.

#### 5.2.1 Shipment by container

The predominant method of transport is by container of which there are two different types for capacity and length: 20' (about 6.1 m) and 40' (about 12.2 m). The standard container used by Embraco Europe is the 20', which allows in comparison to the 40', a higher ratio weight/volume and consequently a better utilization of the internal volume.

Table 16 indicates the characteristics of the load. For each compressor series, indicated are the number of layers, the package number and type for each layer, the total number of compressors and the information on the packaging of equipped components. Occasionally, some freight forwarders in the interest of expediency, prefer to employ a 40' container, even with the disadvantage of total volume utilization.

Table 16 *Load Characteristics for 20' container*

SERIES	FIRST LAYER PACK N° - N° COMP.	SECOND LAYER PACK N° - N° COMP.	THIRD LAYER PACK N° - N° COMP.	TOTAL N° OF COMPRESSORS
<b>EM</b>	14 - 120	14 - 60	(4)	2.520
<b>NB</b>	14 - 72	14 - 72	(4)	2.016
<b>NE<sup>(1)</sup></b>	14 - 72	11 - 72 <sup>(2)</sup>	(4)	1.800
	14 - 72	13 - 72 <sup>(3)</sup>	(4)	1.944
<b>T<sup>(1)</sup></b>	14 - 36	14 - 36	7 - 36 <sup>(4)</sup>	1.260
	14 - 72	14 - 36	(4)	1.512
<b>NJ</b>	14 - 36	11 - 36 <sup>(2)</sup>	(4)	900

(1) The different load structure (1.800 or 1.944 NE series compressors - 1.260 or 1.512 T compressors) is determined by the ratio between the maximum container weight and the compressor weight.  
 (2) No. 3 package filler is added (containing all the equipped components).  
 (3) A package as filler packaging, containing part of the equipped components is added.  
 (4) Type of load which is rarely used. To be avoided due to an incomplete 3rd layer. Packages are added containing the equipped components.

## 5.2.2

### Shipments by truck

The transportation of compressors by truck is the most common system for highway or short distances where the stresses on the product are reduced. This type of transportation, if made without the necessary precautions on load steadiness and travel on uneven roads can cause stresses to compressors with possible damages to the suspension springs and to the internal discharge mufflers. For an Embraco 24,000 kgs (11,000 lb) truck, the load composition is as follows in Table 17:

 Table 17 *Characteristics of load by truck*

SERIES	PACKAGE UNIT TYPE & COMPRESSOR QUANTITY	PACKAGE N°	TOTAL N° OF COMPRESSORS
<b>EM</b>	Throwaway carton of 120 compressors	28 ÷ 32	3.000 ÷ 3.240
<b>EM</b>	Recycling wooden of 120 compressors	28 ÷ 32	3.000 ÷ 3.120
<b>NB-NE</b>	Throwaway carton of 72 compressors	28 ÷ 32	2.016 ÷ 2.304
<b>NB</b>	Recycling wooden of 80 compressors	28 ÷ 32	2.016 ÷ 2.304
<b>T</b>	Throwaway carton of 72 compressors	28 ÷ 32	1.512 ÷ 1.728
<b>NJ</b>	Throwaway carton of 36 compressors	28 ÷ 32	972 ÷ 1.080

**5.3 ACCEPTABLE COMPRESSOR POSITIONS DURING TRANSPORTATION**

For the finished product (compressor assembled in the application), certain transportation conditions do not require that the compressor is positioned upright. Table 18 represents the various acceptable transportation positions. Any position not listed below is prohibited.

Table 18 *Acceptable compressor position during transportation*

SERIES	POSITION					
	Normal (upright)	Label up	Terminal board up	Label down	Terminal board down	Upside-down
EM						
T						
NT						
NB NE						
NJ						

For the solution of potential positioning problems during assembling and transport, please consult the Technical Assistance - Sales Department.

**MAXIMUM ALLOWABLE RATE OF DECELERATION DURING THE TRANSPORT: 1g**

We advise against the transport by rail, even if correctly performed, because during the shunting, stress to the compressors from decelerations can cause stator shifts, or deformation or breaking of brackets and internal discharge tubes.

**5.4**

**STORAGE**

The storage of “multiple packages” can be done by placing one package upon another according to the limits indicated in Table 19 and 20. The maximum allowable height is illustrated on the two sides of the cartons making up the package unit.

Table 19 **Maximum height for multiple throwaway carton packages**

Throwaway packaging: 1 box + shipping skid a1MA015	Throwaway packaging: 2 boxes + shipping skid a1MA023
<p style="text-align: center;"><b>MAX. 5 UNITS</b></p> 	<p style="text-align: center;"><b>MAX. 3 UNITS</b></p> 

Table 20 Maximum height for multiple returnable packages

returnable packages EM-NB-NE Series 80 compr. alM0804	returnable packages EM Series - 120 compressors alM1203	returnable packages EM Series 400 compressors alM1004
<p style="text-align: center;">MAX. 4 UNITS</p> 	<p style="text-align: center;">MAX. 3 UNITS</p> 	<p style="text-align: center;">MAX. 4 UNITS</p> 

All packages must be stored in places protected from humidity and bad weather, as illustrated (open umbrella) on the external sides of the cartons.

**Embraco Europe Srl does not take any responsibility for occasional damages to the package and to the finished product resulting from not observing these instructions.**

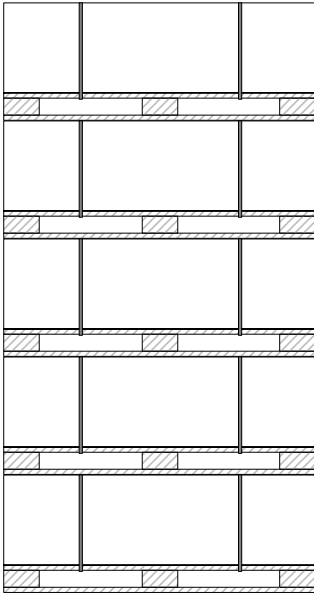
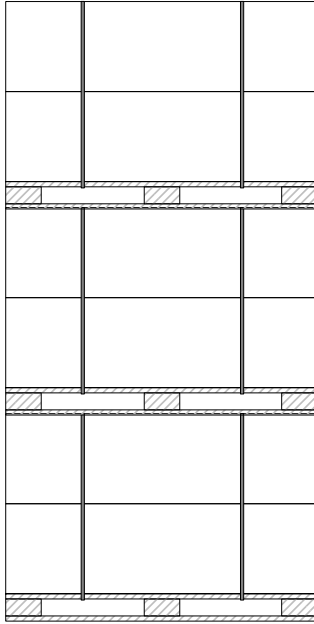
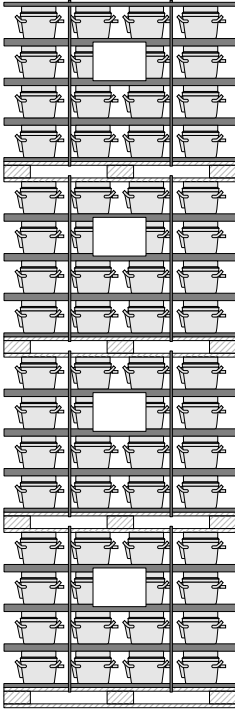
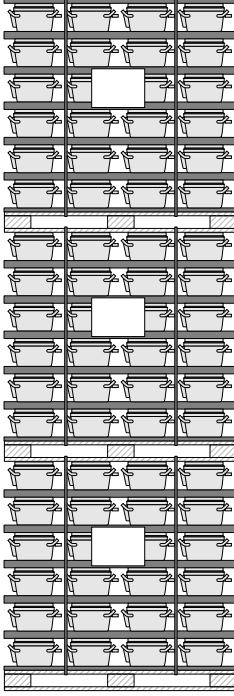
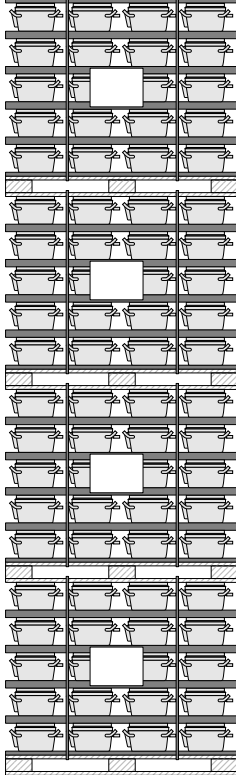
## 6 INFORMATION ABOUT CORRECT COMPRESSOR INSTALLATION

### 6.1 COMPRESSOR SELECTION

The proper selection of the compressor should be made according to the following system characteristics where it will be installed:

- 6.1.1. Minimum evaporating temperature
- 6.1.2. Refrigeration capacity
- 6.1.3. Refrigerant type
- 6.1.4. Ambient temperature
- 6.1.5. Running voltages and frequencies
- 6.1.6. Electric motor starting torque
- 6.1.7. Compressor cooling type
- 6.1.8. Noise level (if applicable)
- 6.1.9. Max current input (if applicable)

Note *For the operational limits of the compressor consult section 7.1.*

#### 6.1.1 Minimum evaporating temperature

The minimum running evaporating temperature of the system, along with the condensing temperature, allows the identification of the compressor application and its refrigeration capacity (see “2- General Information” par. 2.2).

#### 6.1.2 Refrigeration capacity

The required cooling capacity at standard working conditions of the system, in Watt or kcal/h, according to the evaporating and condensing temperatures. The capacity depends on the mass flow rate, which is a function of the compressor displacement, RPM, and volumetric efficiency.

#### 6.1.3 Refrigerant type

Refrigerant selection can be made from the available list taking into consideration the market requirements of the product and ecological factors.

#### 6.1.4 Ambient temperature

The compressor must be selected in order to ensure it is suitable to operate at the maximum required ambient temperature (e.g. temperate climate 32 °C or tropical climate 43 °C).

Compressors are intended for indoor use, and a minimum of 5 °C is required for working, in order to have a correct lubrication. If ambient temperature is around above value and refrigerant charge is approaching or overcoming the maximum allowed limit, can be useful the use of a crankcase heater.

**6.1.5 Operating Voltages and Frequencies**

The compressor must be selected according to the voltage and frequency conditions where the cabinet will operate in the field, considering the voltage field typical of each motor type and their prescribed tolerances. (See “2-General Information” par. 2.5).

**6.1.6 Electric motor starting torque**

The selection of the electric motor starting torque type (low starting torque LST - high starting torque HST) must be made according to the suction and discharge pressures of the system during the compressor start. For systems with capillary tubes or expansion valves with pressure equalization, a low starting torque (LST) is suitable. This compressor does not use a start capacitor, and is able to start only with balanced suction and discharge pressures. For systems with expansion valve where the suction and discharge pressures remain unbalanced, it is necessary to use a high starting torque compressor (HST). See what prescribed under par. “7.1.6 - Start conditions”.

**6.1.7 Compressor cooling type**

Smaller compressors, with relatively low power motors, can be used in a static cooled arrangement. Compressors with higher power motors require forced ventilation. Some compressors in the E and T series are also available with an oil cooler. This oil cooler is a coil positioned in the lower part of the housing immersed in the oil sump. (See “2.7 - COMPRESSOR COOLING TYPES”).

**6.1.8 Noise level**

In some applications the noise level of the system is a consideration. Certain compressors have been developed specifically for low noise applications. In order to select the best compressor for a given application, noise tests of the complete system should be performed as the total noise level is related to the integration of all components and the circulation of the refrigerant.

**6.1.9 Maximum current input**

If there are restrictions on the current absorbed by the compressor and/or on the short circuit current LRA, you may choose a compressor which meets the requested requirements.

---

**6.2 COMPRESSOR UNPACKING**

Remove the compressor from the package keeping it in an upright position to avoid damage. Failure to maintain the compressor in an upright position can result in the introduction of oil into the suction and process connection, possibly causing welding problems. Another more serious consequence can be the breaking of reed valves during compressor start due to oil and the suction muffler. For the same reason, the compressor must remain upright while assembling the grommets and sleeves to the base plate.



**6.3**
**PREPARATION OF REFRIGERATING SYSTEM COMPONENTS**

The cleaning (solid substances and non-condensable) and the reduced moisture in all the components of the refrigeration system, are the primary concerns for the compressor good running and life.

With the introduction of R134a and R404A refrigerants, using new polyolester oils, Embraco Europe adopted strict limits in comparison with CFC - HCFC refrigerants. By introducing some modifications to the production line, a drastic reduction of the moisture content and solid non-condensable residue in the compressors was achieved. Furthermore, in all production processes of Embraco Europe and of external suppliers, all non-compatible products that may contaminate the new refrigerants and the new polyolester oils have been eliminated. These include all chlorine based compounds, as well as non ester based oils. For the same reason, Embraco Europe suggests the use of system components such as tubes, condensers, evaporators, oil separators, liquid receivers, valves, capillaries, etc., to have a moisture and solid and non-condensable residuals contents reduced by 50% in comparison to what is prescribed by DIN 8964 Standard - and free of the contaminants mentioned in the previous paragraph.

**We suggest that the components remain sealed as long as possible before their assembly, performing the welding no later than 15 minutes from assembling the components.**

To avoid oil residuals during the welding process, it can be useful to blow out these components with nitrogen or dry air, with a dew point lower than -40 °C, before using them. These instructions can be taken as a reference also for systems using CFC - HCFC refrigerants (R12-R22-R502- etc.) and isobutane (R600a), even if these refrigerants do not require such strict requirements as R134a and R404A.

We suggest removing the rubber plugs from the tubes of the upright compressor in the following sequence: discharge tube, suction tube and service tube.

A different sequence can cause oil being carried out of the compressor by the internal pressurization. This can cause subsequent welding difficulties on the tubes and internal contamination due to oil residues.

The internal oiling of the tubes can make the welding difficult, and moreover it can introduce contaminants into the system due to "oil cracking".

**Embraco Europe Srl is not responsible for any damage to the compressor caused by the use of inappropriate components and production processes and products not compatible with the new refrigerants and lubrication oils.**

On page 62, Table 32 indicates the possible problems in the system coming from a residual moisture content higher than the above indicated limits. As residual moisture, moisture remaining in the running system may not be absorbed by the molecular sieve of the filter.

Doc. Code	Emission	Revision	Date	Page
MP01EH	2000-04	07	2010-02	47 - 98

6.4

**REFRIGERANT USE GUIDE**

Access to information about, and application of, the new refrigerants allows the manufacture reliable equipment that is correctly dimensioned and operates under safe conditions.

In this section, presented are some guidelines for the use of the following refrigerants: R134a - R600a - R404A - R407C - R290.

**Because of the vast differences between systems and different working fields typical of each application, the reliability of the equipment should be defined by appropriate life and field tests.**

**All operations related to the use of refrigerants should be performed in accordance with local laws and rules related to this subject.**

## 6.4.1 Guide for the use of R134a

### 6.4.1.1 General information

The R134a refrigerant (1.1.2.2 - tetrafluoroethylene) is used to replace the R12 in applications with low, medium and high evaporator temperatures.

 Table 21 **R134a Physical Characteristics**

<b>Molecular Weight</b>	102	(Ref.: R 12 = 120.9)
<b>Critical Temperature</b>	101.1 °C	(Ref.: R 12 = 111.8 °C)
<b>Critical Pressure</b>	40.6 bar	(Ref.: R 12 = 41.1 bar)
<b>Boiling Point</b>	-26.5 °C	(Ref.: R 12 = -29.8 °C)

 Table 22 **R134a Ecological Characteristics**

<b>ODP (Ozone Depletion Potential)</b>	0	(Ref.: R 12 = 1)
<b>GWP (Global Warming Potential)</b>	1300 (100 years)	(Ref.: R 12 = 8501)

### 6.4.1.2 System components compatibility

All refrigeration system components should be compatible with the refrigerant and lubricant used in the compressor. Substances containing **chlorine, mineral oils, paraffin and silicone** are not approved.

All equipment used in the refrigerator manufacturing process that require lubrication and may come into contact with the refrigeration system components, must use exclusively polyolester oil as a lubricant (suggested viscosity 18 - 20cSt @ 40 °C). Due to the strict requirements associated with the use of the R134a, particular attention must be given to the internal cleanliness of the system. The above mentioned substances as well as any solid residues (dust, metal particles, etc...) must not be introduced into the system. It is recommended that the maximum level of the contamination should be 50% less than what is prescribed in norm **DIN 8964<sup>(1)</sup>**.

### 6.4.1.3 Expansion device

**Capillary tubes:** For a new application, the first component to be dimensioned should be the capillary tube. To prepare the prototype, use chapter 6.6 - Capillary Tubes Selection as a reference.

As a general rule, to convert a system from R-12 to R134a, the same capillary tube may be used.

**It is not recommended to use a capillary tube with an internal diameter less than 0.6 mm.**

For each system, the optimal dimensioning of the capillary tube should be performed in an appropriate test laboratory in order to obtain the best working conditions, and to avoid the return of liquid refrigerant to the compressor.

**Expansion Valve:** Should be selected according to the working temperatures and pressure characteristics of refrigerant R134a.

### 6.4.1.4 Evaporator and condenser

Generally to convert a system from R-12 to R134a, the same evaporator and condenser tube may be used.

(1) The soluble residual contents and solid residues must be less than 100mg/m<sup>2</sup> of system internal surface area. Of this, a maximum of 40 mg/m<sup>2</sup> can be soluble and the maximum of 60mg/m<sup>2</sup> can be insoluble (for the definitions of solid/soluble and additional details refer to the norm mentioned above).

**6.4.1.5 Filter dryer**

It is recommended to use a filter dryer, such as XH7, that is compatible with the refrigerant R134a and the compressor oil. (Refer to chapter 6.5 - Selection of the Filter Dryer).

The filter should have a molecular sieve of no less than 3 Angstrom.

It is suggested to increase the mass of the molecular dryer 15 to 20%, compared to the one used with refrigerant R 12.

Always consult the manufacturer for the proper selection of a filter dryer.

**6.4.1.6 Evacuation and charging equipment**

Generally the vacuum level for a R134a system is the same used for a system with R 12.

Good refrigeration practice suggests system evacuation from both low side and high side, achieving a minimum level of 0.14 mbar (100 µHg) with a non-condensable value of less than 0.3% by volume.

Use charging equipment suitable for use of the refrigerant R134a, and if possible, dedicate this machine for use only with refrigerant R134a.

**6.4.1.7 Refrigerant charge**

Generally the quantity of the refrigerant R134a introduced into the system can be reduced from 5 to 20%, compared to the required charge of R 12.

For each system, the optimal refrigerant charge should be determined in an appropriate test laboratory in order to obtain the best working conditions, and to avoid the return of liquid refrigerant to the compressor.

Refrigerant R134a should not have any contamination; even a small amount of a Chlorine based refrigerant can cause problems.

**6.4.1.8 Moisture**

In order to avoid problems that can shorten life of the refrigeration system, use components that are supplied internally dried and properly sealed to prevent the entrance of moisture. These components should remain sealed until they are used.

It is recommended to avoid leaving the compressor and components exposed to the ambient for more than 15min.

If there is doubt about the presence of moisture in a component; it may be dried by blowing dry air (with a dew point below -40 °C) through the internal surface for a sufficient time period.

It is recommended to maintain moisture content in the system 50% lower than it is prescribed by norm DIN8964.

The level of moisture present in the refrigeration circuit should be below 40ppm and after the system has been operating, the filter dryer should remove moisture from the system from a level below 20ppm.

**6.4.1.9 Leak control**

It is recommended that special attention be given to the correct welding of the system components to avoid the possibility of leaks. This is due to the smaller molecular dimensions of refrigerant R134a.

To guarantee the maximum efficiency in controlling leaks, it is recommended to use a leak detector designed for use with refrigerant R134a, or as an alternative, a detector designed for use with Helium.

**6.4.1.10 Equalization time for suction and discharge pressures**

The use of the refrigerant R134a requires significantly more time for the suction and discharge pressures to equalize compared to R 12. Because of this, the compressor should be selected accordingly to allow for this longer equalization time.

**6.4.1.11 High pressure limit control**

To protect the system, it may be necessary to install a high pressure limit switch to control the maximum discharge pressure. The settings on this limit switch should be in accordance with the limits established in Chapter 7.1.3 - Discharge gas maximum pressures.

## 6.4.2 Guide for the use of R600a

### 6.4.2.1 General information

The refrigerant R600a (isobutane) is used to substitute R 12 as an alternative to R 134a, primarily in domestic refrigerators and freezers.

Before supplying compressors for use with R600a, it is first necessary to perform an evaluation of the risks involved with the use of this refrigerant. The customer should perform a risk assessment to ensure proper knowledge about the handling and use of the R600a in the refrigerant system ( for further information please contact the Technical Assistant Department at Embraco Europe).

When converting a system from R12 to R600a, the displacement of the compressor is increased by approximately 90% while the charge of the refrigerant is reduced by 50%.

Table 23 **R600a Physical characteristics**

<b>Recommended Purity</b>	99.5%	
<b>Maximum Allowable Impurities</b>	Propane 0.2% maximum, Air 100 pp max, Water 10 ppm max, Silicon Oil 5 ppm max, Sulphur and compounds 1 ppm max, Nbutane 0.3% max.	
<b>Molecular Weight</b>	58.1	(Ref.: R 12 = 120.9)
<b>Critical Temperature</b>	134.7 °C	(Ref.: R 12 = 111.8 °C)
<b>Critical Pressure</b>	36.5 bar	(Ref.: R 12 = 41.1 bar)
<b>Boiling Point</b>	-11.7 °C	(Ref.: R 12 = -29.8 °C)
<b>Flammability in Air</b>	Minimum limit. LEL = 1.8% in vol.; Maximum limit UEL = 8.5% in vol.	

Table 24 **R 600a Ecological Characteristics**

<b>ODP (Ozone Depletion Potential)</b>	0	(Ref.: R 12 = 1)
<b>GWP (Global Warming Potential)</b>	3 (100 years)	(Ref.: R 12 = 8501)

**PLEASE NOTE:** R600a is flammable and should then be handled by qualified personnel in accordance with the rules and regulations now established for safe use.

### 6.4.2.2 System component compatibility

All of the components in the refrigeration system that may contain contaminants, should conform to the requirements outlined in norm DIN8964<sup>(1)</sup>. The presence of the contaminants paraffin and silicon are not permitted.

### 6.4.2.3 Expansion device

Generally, when changing a system from R12 to R600a, the same capillary tube can be used.

It is not recommended to use a capillary tube with an internal diameter less than 0.6 mm.

For each system the optimal dimensioning of the capillary tube should be performed in an appropriate test laboratory, in order to obtain the best working conditions.

(1) The soluble residual contents and solid residues must be less than 100mg /m<sup>2</sup> of system internal surface area. Of this, a maximum of 40 mg/m<sup>2</sup> can be soluble and the maximum of 60mg /m<sup>2</sup> can be insoluble (for the definitions of solid/ soluble and additional details refer to the norm mentioned above).

**6.4.2.4 Evaporator and condenser**

Generally to convert a system from R-12 to R600a, the same evaporator and condenser may be used.

The internal circuit of the evaporator should be verified because there may be regions that may tend to trap oil and can temporarily prevent refrigerant flow.

**6.4.2.5 Filter dryer**

Refrigerant R600a requires the use of a normal filter drier type 4A-XH5 or better (see chapter 6.5 - Filter Dryer).

Always consult the manufacturer for the proper selection of the filter drier.

**6.4.2.6 Evacuation and charging equipment**

Generally the vacuum level for a R600a system is the same used for a system with R 12.

Good refrigeration practice suggests system evacuation from both low side and high side and achieving a minimum level of 0.14 mbar (100 µHg) with a non condensable value of less than 0.3% by volume.

Use charging equipment suitable for use of the refrigerant R600a.

**6.4.2.7 Refrigerant charge**

Generally the quantity of the refrigerant R600a introduced into the system can be reduced from 50-60% compared to the required charge of R 12.

This characteristic greatly reduces the legal risk of flammability of the refrigerant in case of a system leak.

For each system, the optimal refrigerant charge should be determined in an appropriate test laboratory in order to obtain the best working conditions.

**6.4.2.8 Moisture**

In order to avoid problems that can shorten life of the refrigeration system, use components that are internally dry and properly sealed to prevent the entrance of moisture. These components should remain sealed until they are used.

The moisture content in a system should conform to norm DIN8964. The level of moisture present in the refrigeration circuit should be below 40ppm and after the system has been operating, the filter dryer should remove moisture from the system from a level below 20ppm.

**6.4.2.9 Leak control**

It is recommended that special attention be given to the correct welding, or other forms of union of the system components, to avoid the possibility of leaks.

To guarantee the maximum efficiency in controlling leaks, it is recommended to use a leak detector designed for use with refrigerant R600a, or as an alternative, a detector designed for use with Helium.

## 6.4.3 Guide for the use of R404A

### 6.4.3.1 General information

Refrigerant R404A can normally be used as a substitute to the following refrigerants:

- R22 for applications in medium temperatures
- R502 for applications in low temperatures

Table 25 **R 404A Physical Characteristics**

<b>Near-azeotropic Mixture - Three HFC components</b>		
<b>R 125</b> (pentafluorethane) 44%	<b>R 143a</b> (111-trifluorethane) 52%	<b>R 134a</b> (1112 tetrafluorethane) 4%
<b>Boiling Point Temperature</b> -46.3 °C		(Ref.: R 12 = -29.8 °C)
<b>Glide</b> ( $\Delta$ evaporation temperature for the three components) = < 0,5 °C		

Table 26 **R 404A Ecological Characteristics**

<b>ODP (Ozone Depletion Potential)</b>	0	(Ref.: R 22 = 0,05)
<b>GWP (Global Warming Potential)</b>	3750 (100 years)	(Ref.: R 22 = 1700; R 502 = 5590)

### 6.4.3.2 System components compatibility

All refrigeration system components should be compatible with the refrigerant and lubricant used in the compressor. Substances containing **chlorine, mineral oils, paraffin and silicone** are not approved.

All equipment used in the refrigerator manufacturing process that require lubrication and may come into contact with the refrigeration system components, must use exclusively Polyolester oil as a lubricant (suggested viscosity 18 - 20 cSt @ 40 °C). Due to the strict requirements associated with the use of the R404A, particular attention must be given to the internal cleanliness of the system. The above-mentioned substances as well as any solid residues (dust, metal particles, etc...) must not be introduced into the system.

It is recommended that the maximum level of the contamination should be 50% less than what is prescribed in norm **DIN 8964**<sup>(1)</sup>.

### 6.4.3.3 Expansion device

**Capillary tubes:** For a new application, the first component to be dimensioned should be the capillary tube. To prepare the prototype, use chapter 6.6 - Capillary Tubes Selection as a reference.

Generally, to convert a system from R502/R22 to R404A, the same capillary tube may be used.

It is not recommended to use a capillary tube with an internal diameter less than 0.6 mm.

For each system, the optimal dimensioning of the capillary tube should be performed in an appropriate test laboratory in order to obtain the best working conditions, and to avoid the return of liquid refrigerant to the compressor.

**Expansion Valve:** Should be selected according to the working temperatures and pressure characteristics of refrigerant R404A.

(1) The soluble residual contents and solid residues must be less than 100mg /m<sup>2</sup> of system internal surface area. Of this, a maximum of 40 mg/m<sup>2</sup> can be soluble and the maximum of 60mg /m<sup>2</sup> can be insoluble (for the definitions of solid/soluble and additional details refer to the norm mentioned above).



#### 6.4.3.4 Evaporator and condenser

The operating pressures of R404A are higher than those of R22 and R502 and therefore require a larger condenser and evaporator than the systems using R22 or R502.

#### 6.4.3.5 Filter dryer

It is recommended to use a filter dryer, such as XH9, that is compatible with the refrigerant R404A and the compressor oil. (Refer to chapter 6.5 - Selection of the Filter Dryer).

The filter should have a molecular sieve of no less than 3 Angstroms.

It is suggested to increase the mass of the molecular dryer 15 to 20%, compared to the one used with refrigerant R502/R22.

Always consult the manufacturer for the proper selection of a filter dryer.

#### 6.4.3.6 Evacuation and charging equipment

Generally the vacuum level for an R404A system is the same used for a system with R502/R22.

Good refrigeration practice suggests system evacuation from both low side and high side, achieving a minimum level of 0.14 mbar (100 µHg), with a non-condensable value of less than 0.3% by volume.

Use charging equipment suitable for use of the refrigerant R404A, and if possible, dedicate this machine for use only with refrigerant R404A.

#### 6.4.3.7 Refrigerant charge

Generally, the quantity of the refrigerant R404A introduced into the system can be reduced to 80-90% compared to the required charge of R502/R22.

For each system the optimal refrigerant charge should be accurately defined (reduced to the minimum necessary) only after performing appropriate laboratory tests have been performed on the system. This must be done in order to obtain the best working conditions and to avoid the return of liquid refrigerant to the compressor during running and the migration of gas during the off-cycle.

Refrigerant R404A should not have any contamination; even a small amount of a Chlorine-based refrigerant can cause problems.

Refrigerant R404A, a near-azeotropic mixture, must be charged into the system only in the liquid phase to guarantee that the composition of the refrigerant remains constant.

#### 6.4.3.8 Moisture

In order to avoid problems that can shorten life of the refrigeration system, use components that are internally dry and properly sealed to prevent the entrance of moisture. These components should remain sealed until they are used.

It is recommended to avoid leaving the compressor and components exposed to the ambient for more than 15min.

If there are doubts about the presence of moisture in a component, it may be dried by blowing dry air (with a dew point below -40 °C) through the internal surface for a sufficient time period.

It is recommended to maintain moisture content in the system 50% lower than it is prescribed by norm **DIN8964**<sup>(1)</sup>.

The level of moisture present in the refrigeration circuit should be below 40ppm. After the system has been operating, the filter dryer should remove moisture from the system from a level below 20ppm.

#### **6.4.3.9 Leak control**

It is recommended that special attention be given to the correct welding of the system components to avoid the possibility of leaks. This is due to the smaller molecular dimensions of refrigerant R404A.

To guarantee the maximum efficiency in controlling leaks, it is recommended to use a leak detector designed for use with refrigerant R404A, or as an alternative, a detector designed for use with Helium.

**Note: Do not make a mixture of R404A and air to control leaks in the system.**

#### **6.4.3.10 High pressure limit control**

To protect the system, it may be necessary to install a high pressure limit switch to control the maximum discharge pressure. The settings on this limit switch should be in accordance with the limits established in Chapter 7.1.3 - Discharge gas maximum pressures.

(1) The soluble residual contents and solid residues must be less than 100mg/m<sup>2</sup> of system internal surface area. Of this, a maximum of 40 mg/m<sup>2</sup> can be soluble and the maximum of 60mg /m<sup>2</sup> can be insoluble (for the definitions of solid/soluble and additional details refer to the norm mentioned above).

## 6.4.4 Guide for the use of R407C

### 6.4.4.1 General information

Refrigerant R407C can normally be used as a substitute for refrigerant R22 in applications for air conditioning and medium and high temperature applications.

 Table 27 **R 407C Physical Characteristics**

<b>Zeotropic Mixture - Three HFC components</b>		
<b>R 134a</b> (1112 tetrafluoroethane) 52%	<b>R 125</b> (pentafluoroethane) 25%	<b>R 32</b> (difluoromethane) 23%
<b>Boiling Point Temperature</b> -43.6 °C		(Ref.: R 12 = -29.8 °C)
<b>Glide</b> ( $\Delta$ evaporation temperature for the three components) = 7.1 °C		

 Table 28 **R 407C Ecological Characteristics**

<b>ODP (Ozone Depletion Potential)</b>	0	(Ref.: R 22 = 0,05)
<b>GWP (Global Warming Potential)</b>	1610 (20 years)	(Ref.: R 22 = 1700)

### 6.4.4.2 System components compatibility

All refrigeration system components should be compatible with the refrigerant and lubricant used in the compressor. Substances containing **chlorine, mineral oils, paraffin and silicone** are not approved.

All equipment used in the refrigerator manufacturing process that require lubrication and may come into contact with the refrigeration system components, must use exclusively Polyolesther oil as a lubricant (suggested viscosity 18 - 20 cSt @ 40 °C).

Due to the strict requirements associated with the use of the R404A particular attention must be given to the internal cleanliness of the system. The above-mentioned substances as well as any solid residues (dust, metal particles, etc...) must not be introduced into the system.

It is recommended that the maximum level of the contamination should be 50% less than what is prescribed in norm **DIN 8964**<sup>(1)</sup>

### 6.4.4.3 Expansion device

For a new application, the first component to be dimensioned should be the capillary tube. To prepare the prototype, use chapter 6.6 - CAPILLARY TUBES as a reference.

Generally to convert a system from R22 to R407C, the same capillary tube may be used.

For each system, the optimal dimensioning of the capillary tube should be performed in an appropriate test laboratory in order to obtain the best working conditions, and to avoid the return of liquid refrigerant to the compressor.

(1) The soluble residual contents and solid residues must be less than 100mg/m<sup>2</sup> of system internal surface area. Of this, a maximum of 40 mg/m<sup>2</sup> can be soluble and the maximum of 60mg/m<sup>2</sup> can be insoluble (for the definitions of solid/soluble and additional details refer to the norm mentioned above).

**6.4.4.4 Evaporator and condenser**

The operating pressures of R407C are higher than those of R22, and therefore, require a larger condenser than the systems using R22.

**6.4.4.5 Filter dryer**

It is recommended to use a filter dryer, such as XH7, that is compatible with the refrigerant R407C and the compressor oil. (refer to chapter 6.5 - Filter Dryer).

The filter should have a molecular sieve of no less than 3 Angstroms.

It is suggested to increase the mass of the molecular dryer 15% ÷ 20% compared to the one used with refrigerant R22.

Always consult the manufacturer for the proper selection of a filter dryer.

**6.4.4.6 Evacuation and charging equipment**

Generally the vacuum level for an R407C system is the same used for a system with R22.

Good refrigeration practice suggests system evacuation from both low side and high side, achieving a minimum level of 0.14 mbar (100 µHg) with a non-condensable value of less than 0.3% by volume.

Use charging equipment suitable for use of the refrigerant R407C, and if possible, dedicate this machine for use only with refrigerant R407C.

**6.4.4.7 Refrigerant charge**

Generally the quantity of the refrigerant R134a introduced into the system can be reduced to 80%-90% compared to the required charge of R22.

For each system, the optimal refrigerant charge should be accurately defined (reduced to the minimum necessary) only after executing appropriate laboratory tests have been performed on the system. This must be done in order to obtain the best working conditions and to avoid the return of liquid refrigerant to the compressor during running and the migration of gas during the off-cycle.

Refrigerant R407C should not have any contamination. Even a small amount of a Chlorine-based refrigerant can cause problems.

Refrigerant R407C, a zeotropic mixture, must be charged into the system only in the liquid phase to guarantee that the composition of the refrigerant remains constant.

**6.4.4.8 Moisture**

In order to avoid problems that can shorten life of the refrigeration system, use components that are internally dry and properly sealed to prevent the entrance of moisture. These components should remain sealed until they are used.

It is recommended to avoid leaving the compressor and components exposed to the ambient for more than 15min.

If there are doubts about the presence of moisture in a component, it may be dried by blowing dry air (with a dew point below -40 °C) through the internal surface for a sufficient time period.

It is recommended to maintain moisture content in the system 50% lower than it is prescribed by norm **DIN 8964**<sup>(1)</sup>.

(1) The soluble residual contents and solid residues must be less than 100mg/m<sup>2</sup> of system internal surface area. Of this a maximum of 40 mg/m<sup>2</sup> can be soluble and the maximum of 60mg /m<sup>2</sup> can be insoluble (for the definitions of solid/ soluble and additional details refer to the norm mentioned above).

The level of moisture present in the refrigeration circuit should be below 40ppm. After the system has been operating, the filter dryer should remove moisture from the system from a level below 20ppm.

**6.4.4.9 Leak control**

It is recommended that special attention be given to the correct welding of the system components to avoid the possibility of leaks. This is due to the smaller molecular dimensions of refrigerant R407C.

To guarantee the maximum efficiency in controlling leaks, it is recommended to use a leak detector designed for use with refrigerant R407C - R134a, or as an alternative, a detector designed for use with Helium.

**Note: Do not use a mixture of R407C and air to control leaks in the system.**

**6.4.4.10 High pressure limit control**

To protect the system, it may be necessary to install a high pressure limit switch to control the maximum discharge pressure. The settings on this limit switch should be in accordance with the limits established in Chapter 7.1.3 - Discharge gas maximum pressures.

## 6.4.5 Guide for the use of R290

### 6.4.5.1 General information

The refrigerant R290 (propane) is used to substitute R22, as well as R404A, for low and medium back pressure applications, and air conditioning.

Before supplying compressors for use with R290, it is first necessary to perform an evaluation of the risks involved with the use of this refrigerant. The customer should perform a risk assessment to ensure proper knowledge about the handling and use of the R290 in the refrigerant system (for further information please contact the Technical Assistant Department at Embraco Europe).

Refrigerant R290 can normally be used in the same compressor designed for use with R22, but with a different (hermetic type) thermal overload protector.

Tabella 29 **R290 Physical Characteristics**

<b>Molecular Weight</b>	44.1 kg / kmole	(Ref.: R 22 = 86.5)
<b>Critical Temperature</b>	96.8 °C	(Ref.: R 22 = 96.1 °C)
<b>Critical Pressure</b>	42.5 bar	(Ref.: R 22 = 49.8 bar)
<b>Boiling Point</b>	-42.1 °C	(Ref.: R 22 = -40.8 °C)
<b>Flammability in Air</b>	Minimum limit. LEL = 2.1% in vol.; Maximum limit UEL = 9.5% in vol.	

Table 30 **R290 Ecological Characteristics**

<b>ODP (Ozone Depletion Potential)</b>	0	(Ref.: R 22 = 0.05)
<b>GWP (Global Warming Potential)</b>	3 (100 years)	(Ref.: R 22 = 1700)

**PLEASE NOTE:** R290 is flammable and should then be handled by qualified personnel in accordance with the rules and regulations now established for safe use.

### 6.4.5.2 System component compatibility

All of the components in the refrigeration system that may contain contaminants should conform to the requirements outlined in norm **DIN 8964<sup>(1)</sup>**.

The presence of the contaminants **paraffin and silicon** is not permitted.

### 6.4.5.3 Expansion device

For a new application the first component to be dimensioned should be the capillary tube. To prepare the prototype, use chapter 6.6 - **CAPILLARY TUBES** as a reference.

Generally, when changing a system from R22 to R290, the same capillary tube can be used although the length should be decreased by approximately 5%.

It is not recommended to use a capillary tube with an internal diameter less than 0.6 mm.

For each system the optimal dimensioning of the capillary tube should be performed in an appropriate test laboratory, in order to obtain the best working conditions.

### 6.4.5.4 Evaporator and condenser

Generally to convert a system from R22 to R290, the same evaporator and condenser may be used.

(1) The soluble residual contents and solid residues must be less than 100mg/m<sup>2</sup> of system internal surface area. Of this, a maximum of 40 mg/m<sup>2</sup> can be soluble and the maximum of 60mg/m<sup>2</sup> can be insoluble (for the definitions of solid/soluble and additional details refer to the norm mentioned above).

**6.4.5.5 Filter dryer**

Refrigerant R290 requires the use of a normal filter drier type XH-9 (See Chapter 6.5 - Filter Dryer)

Always consult the manufacturer for the proper selection of the filter drier.

**6.4.5.6 Evacuation and charging equipment**

Generally the vacuum level for an R290 system is the same used for a system with R22.

Good refrigeration practice suggests system evacuation from both low side and high side, achieving a minimum level of 0.14 mbar (100  $\mu$ Hg) with a non-condensable value of less than 0.3% by volume.

Use charging equipment suitable for use of the refrigerant R290, and if possible, dedicate this equipment for use only with this refrigerant.

**6.4.5.7 Refrigerant charge**

Generally the quantity of the refrigerant R600a introduced into the system can be reduced from 50% ÷ 60% compared to the required charge of R22.

This characteristic greatly reduces the legal risk of flammability of the refrigerant in case of a system leak.

For each system the optimal refrigerant charge should be determined in an appropriate test laboratory in order to obtain the best working conditions.

**6.4.5.8 Moisture**

In order to avoid problems that can shorten life of the refrigeration system, use components that are supplied internally dried and properly sealed to prevent the entrance of moisture. These components should remain sealed until they are used.

The moisture content in a system should conform to norm **DIN 8964**<sup>(1)</sup>.

The level of moisture present in the refrigeration circuit should be below 40ppm and after the system has been operating, the filter dryer should remove moisture from the system from a level below 20ppm.

**6.4.5.9 Leak control**

It is recommended that special attention be given to the correct welding, or other forms of union of the system components, to avoid the possibility of leaks.

To guarantee the maximum efficiency in controlling leaks, it is recommended to use a leak detector designed for use with refrigerant R290, or as an alternative, a detector designed for use with Helium.

**6.4.5.10 High pressure limit control**

To protect the system, it may be necessary to install a high pressure limit switch to control the maximum discharge pressure. The settings on this limit switch should be in accordance with the limits established in Chapter 7.1.3 - Discharge gas maximum pressures.

(1) The soluble residual contents and solid residues must be less than 100mg/m<sup>2</sup> of system internal surface area. Of this a maximum of 40 mg/m<sup>2</sup> can be soluble and the maximum of 60mg /m<sup>2</sup> can be insoluble (for the definitions of solid/soluble and additional details refer to the norm mentioned above).

## 6.5 FILTER DRYER

The filter drier must be chosen with the molecular sieve suitable to the refrigerant type used in the system as indicated in the Table 31.

Table 31 *Suggested Filter Dryer*

REFRIGERANT	MOLECULAR SIEVE
R 12 - R 600a	4A-XH-5 (8 × 12)
R 22 - R 502 (R 12 - R 600a)	4A-XH-6 (8 × 12)
R 134a (R 12 - R 600a - R 407C)	XH-7 (8 × 12)
R 404A - R 402A- R 402B - R 401A - R 401B - R 507 - R 290 (R 12 - R 600a - R 134a - R 22 - R 502 - R 407C)	XH-9 (8 × 12)

For the applications with R134a - R404A, we suggest to increase the weight of the molecular sieve by 10% ÷ 15% compared to the corresponding applications with R12 - R502. The filter drier must be properly protected from absorption of ambient humidity during assembly of the system according to the following practices:

- Remove the protection caps from the filter shortly before welding.
- The filters supplied without protection caps, in “blister” or in “hermetic boxes” must be duly protected to avoid moisture absorption before welding.

**A reduced absorption capacity can cause an incomplete water absorption by the molecular sieve, therefore, the moisture could circulate freely in the system with the following effects indicated in Table 32.**

Table 32 *Inconvenient caused by moisture in the system*

<b>1 Ice build-up:</b>	Reduces the cross-sectional area of the capillary tube, or expansion valve, up to their complete obstruction.
<b>2 Acid build-up:</b>	Causes serious problems in the compressor and to the molecular sieve of the filter. Typical marks and consequences are: <ul style="list-style-type: none"> <li>• Copper plating of valve plate, valve reeds, crankshaft bearings, etc.</li> <li>• Etching of electric motor insulation by acids, with burning of motor windings.</li> <li>• Destruction of the filter with disintegration of molecular sieve and build-up of “dusts”.</li> <li>• Wears and blocks alternative and rotating mechanical parts.</li> </ul>
<b>3 Oil contamination:</b>	Causes acidification and reduction of its lubricating power, with change of oil color (brown). It can cause build-up of sludge, with subsequent poor lubrication of compressor.



**6.6 CAPILLARY TUBES**

During the initial steps of the design of a new cabinet Table 33 can provide a helpful guidance for selecting the most appropriate capillary tube dimensions to start with. The exact size of the capillary must however be found according to the results of the laboratory tests performed on the prototype cabinets.

The values, indicated on Table 33, have been determined according to the following considerations:

- **LBP-MBP-HBP Applications:** with heat exchanger of minimum length 0.9 m and with 0 °C sub-cooling.
- **Air Conditioning Applications:** with condensing temperature of 54 °C, sub-cooling of 8 °C, return gas temperature 18 °C.

 Table 33 *Choice of Capillary*

<b>R 600a - LBP Applications</b>			
<b>COMPRESSOR</b>	<b>FREQUENCY</b>	<b>DIMENSION</b>	
		<b>(from -30°C to -15°C evap. temp.)</b>	<b>(from -15°C to -5°C evap. temp.)</b>
EMU26CLC	50 Hz	0.66 mm I.D. × 4.00 m	0.66 mm I.D. × 3.45 m
EMT26CLP	50 Hz	0.66 mm I.D. × 3.80 m	0.66 mm I.D. × 3.30 m
EMU32CLC	50 Hz	0.66 mm I.D. × 3.60 m	0.78 mm I.D. × 3.60 m
EMT32CLP	50 Hz	0.78 mm I.D. × 3.60 m	0.91 mm I.D. × 3.60 m
EMT40CLP-EMU40CLC	50 Hz	0.78 mm I.D. × 3.50 m	0.91 mm I.D. × 3.50 m
NBM1112Y - NBT1112Y NBU1112Y EMT45CLP - EMU46CLC	50 Hz	0.78 mm I.D. × 3.40 m	0.91 mm I.D. × 3.40 m
NBM1114Y – NBU1114Y NBT1114Y – EMT56CLP	50 Hz	0.78 mm I.D. × 3.20m	0.91 mm I.D. × 3.20 m
NBK1116Y – NBU1116Y NBT1116Y	50 Hz	0.78 mm I.D. × 3.00 m	0.91 mm I.D. × 3.00 m
NBK1118Y – NBU1118Y NBT1118Y	50 Hz	0.91 mm I.D. × 3.60 m	1.06 mm I.D. × 3.60 m

<b>R22 - LBP Applications</b>			
<b>COMPRESSOR</b>	<b>FREQUENCY</b>	<b>DIMENSION</b>	
		<b>(from -30°C to -5°C evap. temp.)</b>	<b>-</b>
NE2125E	50 Hz	0.91 mm I.D. × 3.2 m	-
	60 Hz	0.91 mm I.D. × 2.85 m	-
NE2134E	50 Hz	0.91 mm I.D. × 2.8 m	-
	60 Hz	0.91 mm I.D. × 2.5 m	-
T2140E	50 Hz	0.91 mm I.D. × 2.6 m	-
	60 Hz	0.91 mm I.D. × 2.3 m	-
T2155E	50 Hz	1.20 mm I.D. × 3.9 m	-
	60 Hz	1.20 mm I.D. × 3.5 m	-
T2168E	50 Hz	1.20 mm I.D. × 3.3 m	-
	60 Hz	1.20 mm I.D. × 2.8 m	-
NJ2178E	50 Hz	1.20 mm I.D. × 3.0 m	-
NJ2190E	50 Hz	1.20 mm I.D. × 2.5 m	-
<b>R22 - MBP/HBP Applications</b>			
<b>COMPRESSOR</b>	<b>FREQUENCY</b>	<b>DIMENSION</b>	
		<b>(from -20°C to -5°C evap. temp.)</b>	<b>(from -5°C to +10°C evap. temp.)</b>
NB6144E	50 Hz	1.06 mm I.D. × 3.5 m	1.06 mm I.D. × 3.0 m
	60 Hz	1.06 mm I.D. × 3.0 m	1.06 mm I.D. × 2.6 m
NB6152E	50 Hz	1.06 mm I.D. × 3.3 m	1.06 mm I.D. × 2.7 m
	60 Hz	1.06 mm I.D. × 2.8 m	1.06 mm I.D. × 2.3 m
NB5165E - NB6152E	50 Hz	1.06 mm I.D. × 3.0 m	1.20 mm I.D. × 3.5 m
	60 Hz	1.06 mm I.D. × 2.6 m	1.20 mm I.D. × 3.0 m
NE5181E - NE6181E	50 Hz	1.20 mm I.D. × 3.2 m	1.20 mm I.D. × 2.5 m
	60 Hz	1.20 mm I.D. × 2.75 m	1.20 mm I.D. × 2.2 m
NE5195E - NE6195E	60 Hz	1.20 mm I.D. × 3.0 m	1.27 mm I.D. × 2.8 m
NE5195E - NE6210E	50 Hz	1.20 mm I.D. × 2.9 m	1.27 mm I.D. × 2.6 m
	60 Hz	1.20 mm I.D. × 2.5 m	1.27 mm I.D. × 2.3 m
NE9213E - NE7213F	50 Hz	1.27 mm I.D. × 2.7 m	1.27 mm I.D. × 1.9 m
	60 Hz	1.27 mm I.D. × 2.35 m	1.27 mm I.D. × 1.65 m
T6217E	50 Hz	1.27 mm I.D. × 2.3 m	1.27 mm I.D. × 1.6 m
T6220E	50 Hz	1.37 mm I.D. × 2.0 m	1.37 mm I.D. × 1.6 m
NJ9226E - NJ9226P - NJ7225F	50 Hz	1.63 mm I.D. × 2.9 m	1.63 mm I.D. × 1.7 m
	60 Hz	1.63 mm I.D. × 2.5 m	1.90 mm I.D. × 1.9 m
NJ7228F - NJ7228P - NJ7228E	50 Hz	1.63 mm I.D. × 2.4 m	1.90 mm I.D. × 1.9 m
	60 Hz	1.90 mm I.D. × 2.5 m	2.16 mm I.D. × 2.0 m
NJ9232E - NJ9232P - NJ7231F NJ7231P	50 Hz	1.90 mm I.D. × 2.8 m	2.16 mm I.D. × 2.2 m
	60 Hz	1.90 mm I.D. × 2.15 m	2.16 mm I.D. × 1.7 m
NJ9238E - NJ9238P NJ7238E - NJ7238P	50 Hz	2.16 mm I.D. × 2.6 m	2 × 1.63 mm I.D. × 1.8 m
	60 Hz	2.16 mm I.D. × 2.0 m	2 × 2.16 mm I.D. × 2.5 m
NJ7240F - NJ7240P	50 Hz	2.16 mm I.D. × 2.3 m	2 × 2.16 mm I.D. × 2.8 m
	60 Hz	2 × 1.63 mm I.D. × 2.0 m	2 × 2.16 mm I.D. × 2.3 m

<b>R 22 - Air Conditioning Applications</b>			
<b>COMPRESSOR</b>	<b>FREQUENCY</b>	<b>DIMENSION</b>	
NE7213E	50 Hz	1.24 mm I.D. × 1.05 m	–
	60 Hz	1.24 mm I.D. × 1.0 m	–
NE7215E	50 Hz	1.24 mm I.D. × 1.0 m	–
	60 Hz	1.24 mm I.D. × 0.95 m	–
T7220E - T7220F	50 Hz	1.37 mm I.D. × 1.0 m	–
	60 Hz	1.37 mm I.D. × 0.95 m	–
T7223E - T7223F	50 Hz	1.5 mm I.D. × 1.05 m	–
	60 Hz	1.5 mm I.D. × 1.0 m	–
NJ7225E - NJ7225F	50 Hz	2.16 mm I.D. × 2.0 m	–
	60 Hz	2.16 mm I.D. × 1.8 m	–
NJ7228E - NJ7228F	50 Hz	2.16 mm I.D. × 1.9 m	–
	60 Hz	2.16 mm I.D. × 1.7 m	–
NJ7231E - NJ7231F - NJ7231P	50 Hz	2.16 mm I.D. × 1.6 m	–
	60 Hz	2.16 mm I.D. × 1.4 m	–
NJ7238E - NJ7238P	50 Hz	2 × 2.16 mm I.D. × 2.5 m	–
	60 Hz	2 × 2.16 mm I.D. × 2.3 m	–
NJ7240E - NJ7240F - NJ7240P	50 Hz	2 × 2.16 mm I.D. × 2.3 m	–
	60 Hz	2 × 2.16 mm I.D. × 2.1 m	–

<b>R134a - LBP Applications</b>			
<b>COMPRESSOR</b>	<b>FREQUENCY</b>	<b>DIMENSION</b>	
		<b>(from -30°C to -15°C evap. temp.)</b>	<b>(from -15°C to -5°C evap. temp.)</b>
EMT22H	50 Hz	0.61 mm I.D. × 4.0 m	0.61 mm I.D. × 3.5 m
EMT36H	50 Hz	0.78 mm I.D. × 4.0 m	0.91 mm I.D. × 4.0 m
EMT43H	50 Hz	0.78 mm I.D. × 3.7 m	0.91 mm I.D. × 3.7 m
EMT49H	50 Hz	0.78 mm I.D. × 3.5 m	0.91 mm I.D. × 3.5 m
NB2116Z - NB1116Z - EMT60H	50 Hz	0.78 mm I.D. × 3.3 m	0.91 mm I.D. × 3.3 m
	60 Hz	0.78 mm I.D. × 2.75 m	0.91 mm I.D. × 2.75 m
NB 1118Z - NB2118Z	50 Hz	0.91 mm I.D. × 4.0 m	1.06 mm I.D. × 4.0 m
	60 Hz	0.91 mm I.D. × 3.3 m	1.06 mm I.D. × 3.3 m

<b>R134a - HBP Applications</b>			
<b>COMPRESSOR</b>	<b>FREQUENCY</b>	<b>DIMENSION</b>	
		<b>(from -15°C to -5°C evap. temp.)</b>	<b>(from -5°C to +10°C evap. temp.)</b>
NB5125Z	50 Hz	0.78 mm I.D. × 2.5 m	0.91 mm I.D. × 2.4 m
	60 Hz	0.78 mm I.D. × 2.1 m	0.91 mm I.D. × 2.0 m
NB5128Z	50 Hz	0.78 mm I.D. × 2.4 m	0.91 mm I.D. × 2.3 m
	60 Hz	0.78 mm I.D. × 2.0 m	0.91 mm I.D. × 1.9 m
NB5132Z - NB6132Z	50 Hz	0.78 mm I.D. × 2.3 m	0.91 mm I.D. × 2.2 m
	60 Hz	0.78 mm I.D. × 1.9 m	0.91 mm I.D. × 1.8 m
NB5144Z - NB6144Z NEK5144Z - EMT6144Z	50 Hz	0.91 mm I.D. × 2.9 m	1.06 mm I.D. × 2.7 m
	60 Hz	0.91 mm I.D. × 2.4 m	1.06 mm I.D. × 2.3 m
NE5160Z - NE6160Z NEK6160Z - EMT6160Z	50 Hz	0.91 mm I.D. × 2.4 m	1.06 mm I.D. × 2.5 m
	60 Hz	0.91 mm I.D. × 2.1 m	1.06 mm I.D. × 2.2 m
NE5170Z - NE6170Z NEK5170Z - NEK6170Z EMT6170Z	50 Hz	1.06 mm I.D. × 3.2 m	1.27 mm I.D. × 3.3 m
	60 Hz	1.06 mm I.D. × 2.65 m	1.27 mm I.D. × 2.75 m
NE5187Z - NE6187Z NEK6187Z	50 Hz	1.24 mm I.D. × 4.0 m	1.37 mm I.D. × 3.3 m
	60 Hz	1.24 mm I.D. × 3.4 m	1.37 mm I.D. × 2.9 m
NE6210Z - NEK6210Z NEK6212Z	60 Hz	1.37 mm I.D. × 3.5 m	1.50 mm I.D. × 3.3 m
	60 Hz	1.37 mm I.D. × 3.3 m	1.50 mm I.D. × 3.1 m
T6213Z	50 Hz	1.37 mm I.D. × 3.5 m	1.50 mm I.D. × 3.3 m
	60 Hz	1.37 mm I.D. × 3.1 m	1.50 mm I.D. × 2.9 m
T6215Z - T6217Z	50 Hz	1.37 mm I.D. × 3.1 m	1.50 mm I.D. × 2.9 m
	60 Hz	1.37 mm I.D. × 2.7 m	1.50 mm I.D. × 2.5 m
NJ6220Z - NJ6220ZX	50 Hz	1.63 mm I.D. × 3.6 m	1.78 mm I.D. × 3.3 m
	60 Hz	1.63 mm I.D. × 3.0 m	1.78 mm I.D. × 2.75 m
NJ6226Z - NJ6226ZX	50 Hz	2 × 1.50 mm I.D. × 4.0 m	2 × 1.63 mm I.D. × 3.0 m
	60 Hz	2 × 1.50 mm I.D. × 3.4 m	2 × 1.63 mm I.D. × 2.5 m

<b>R 290 - R 404A - R 507 - LBP Applications</b>			
<b>COMPRESSOR</b>	<b>FREQUENCY</b>	<b>DIMENSION</b>	
		<b>(from -40°C to -10°C evap. temp.)</b>	<b>-</b>
NEK2121U - NEK2125U NE2125GK - NEK2125GK	50 Hz	0.91 mm I.D. × 4.0 m	-
EMT2121U - EMT2125U EMT2125GK - EMT2125GK	60 Hz	0.91 mm I.D. × 3.5 m	-
NEK2130GK - NEK2134GK NE2134GK - NEK2134U	50 Hz	0.91 mm I.D. × 3.0 m	-
	60 Hz	0.91 mm I.D. × 2.65 m	-
T2140GK - NEK2150U	50 Hz	0.91 mm I.D. × 2.7 m	-
	60 Hz	0.91 mm I.D. × 2.4 m	-
T2155GK	50 Hz	1.20 mm I.D. × 4.1 m	-
	60 Hz	1.20 mm I.D. × 3.6 m	-
T2168GK - NT2168GK	50 Hz	1.20 mm I.D. × 3.4 m	-
	60 Hz	1.20 mm I.D. × 3.0 m	-
T2178GK NT2178GK - NT2160U	50 Hz	1.20 mm I.D. × 3.1 m	-
	60 Hz	1.20 mm I.D. × 2.75 m	-
T2180GK NT2180GK - NT2170U	50 Hz	1.20 mm I.D. × 2.9 m	-
	60 Hz	1.20 mm I.D. × 2.55 m	-
NJ2192GK - NJ2192GS NT2192GK - N2180U	50 Hz	1.40 mm I.D. × 3.5 m	-
	60 Hz	1.40 mm I.D. × 3.1 m	-
NJ2212GK - NJ2212GS NT2212GK	50 Hz	1.60 mm I.D. × 3.5 m	-
	60 Hz	1.60 mm I.D. × 3.1 m	-

<b>R 290 - R 404A - R 507 - MBP Applications</b>			
<b>COMPRESSOR</b>	<b>FREQUENCY</b>	<b>DIMENSION</b>	
		<b>(from -20°C to -5°C evap. temp.)</b>	<b>(from -5°C to +15°C evap. temp.)</b>
NB6144GK - NEK6144GK EMT6144U - EMT6144GK	50 Hz	1.06 mm I.D. × 3.30 m	1.06 mm I.D. × 2.80 m
	60 Hz	1.06 mm I.D. × 2.80 m	1.06 mm I.D. × 2.45 m
NB6152GK - NEK6152U EMT6152U - EMT6152GK	50 Hz	1.06 mm I.D. × 3.10 m	1.06 mm I.D. × 2.55 m
	60 Hz	1.06 mm I.D. × 2.65 m	1.06 mm I.D. × 2.15 m
NB5165GK NB6165GK - NEK6165GK EMT6165U - EMT6165GK	50 Hz	1.06 mm I.D. × 2.80 m	1.20 mm I.D. × 3.30 m
	60 Hz	1.06 mm I.D. × 2.45 m	1.20 mm I.D. × 2.85 m
NE5181GK - NEK6181U NE6181GK - NEK 6181GK	50 Hz	1.20 mm I.D. × 3.00 m	1.20 mm I.D. × 2.35 m
	60 Hz	1.20 mm I.D. × 2.60 m	1.20 mm I.D. × 2.05 m
NE5195GK NE6195GK	60 Hz	1.20 mm I.D. × 2.80 m	1.27 mm I.D. × 2.65 m
NEK 6210U NE6210GK - NEK6210GK	50 Hz	1.20 mm I.D. × 2.75 m	1.27 mm I.D. × 2.45 m
	60 Hz	1.20 mm I.D. × 2.35 m	1.27 mm I.D. × 2.15 m
NEK6213U - NEK6213GK NE9213GK	50 Hz	1.27 mm I.D. × 2.55 m	1.27 mm I.D. × 1.80 m
	60 Hz	1.27 mm I.D. × 2.20 m	1.27 mm I.D. × 1.55 m
T6217GK NT6217U - NT6217GK	50 Hz	1.27 mm I.D. × 2.15 m	1.27 mm I.D. × 1.50 m
	60 Hz	1.27 mm I.D. × 1.85 m	1.37 mm I.D. × 1.60 m
T6220GK NT6220U - NT6220GK	50 Hz	1.37 mm I.D. × 1.90 m	1.37 mm I.D. × 1.50 m
	60 Hz	1.37 mm I.D. × 1.65 m	1.63 mm I.D. × 1.75 m
T6222GK NT6222U - NT6222GK	50 Hz	1.37 mm I.D. × 1.60 m	1.63 mm I.D. × 1.70 m
	60 Hz	1.63 mm I.D. × 2.85 m	1.63 mm I.D. × 1.55 m
NJ9226GK NT6224U - NT6226GK	50 Hz	1.63 mm I.D. × 2.75 m	1.63 mm I.D. × 1.60 m
	60 Hz	1.63 mm I.D. × 2.35 m	1.90 mm I.D. × 1.80 m
NJ9232GK	50 Hz	1.90 mm I.D. × 2.65 m	2.16 mm I.D. × 2.05 m
	60 Hz	1.90 mm I.D. × 2.00 m	2.16 mm I.D. × 1.60 m
NJ9238GK	50 Hz	2.16 mm I.D. × 2.45 m	2×1.63 mm I.D. × 1.70 m
	60 Hz	2.16 mm I.D. × 1.90 m	2×2.16 mm I.D. × 2.35 m

**6.7 APPLICATION OF RUBBER GROMMETS**

Alternating forces of first order, such as rotating masses and masses having rectilinear and alternating motion, are duly balanced inside the compressor. Inertial alternating forces of greater order are not balanced, however, they are partially absorbed by the internal suspension springs and partially by the rubber grommets, when correctly applied to the external mounting base. The rubber grommets and the sleeves, have been selected in order to guarantee the following characteristics:

- Reduction of vibrations transmission of more than 50%.
- Absorption of inertial, tangential forces and relative moments, particularly noticeable at compressor, start and stop.

The components of this external suspension system are supplied partly by Embraco Europe (rubber grommets and sleeves) while the remaining components for their blocking screws, washers and nuts (or suitable alternate systems), must be furnished by the customer. It is very important that these components be assembled correctly in order to guarantee, as indicated in Figure 30, the proper clearance between the rubber grommet and flat washer, fixed between nut and sleeve. This clearance allows the improved damping of the vibrations transmitted by the compressor, isolating it from base plate. For each compressor series, a rubber grommet has been defined to be coupled to the relative sleeve as indicated in Table 34.

**PLEASE NOTE:** The use of grommets and sleeves different from the ones designated may decrease the absorption of vibration resulting in a subsequent noise increase.

Legend 6 **Rubber Grommets Assembling Process**

<b>A</b> Washer	<b>E</b> Mounting Base
<b>B</b> Gap	<b>G</b> Clip
<b>C</b> Sleeve	<b>H</b> Screw M6 (M8)
<b>D</b> Grommets	<b>I</b> Pin
<b>E</b> Base plate	

Figure 30 **Rubber Grommets Assembling Process**

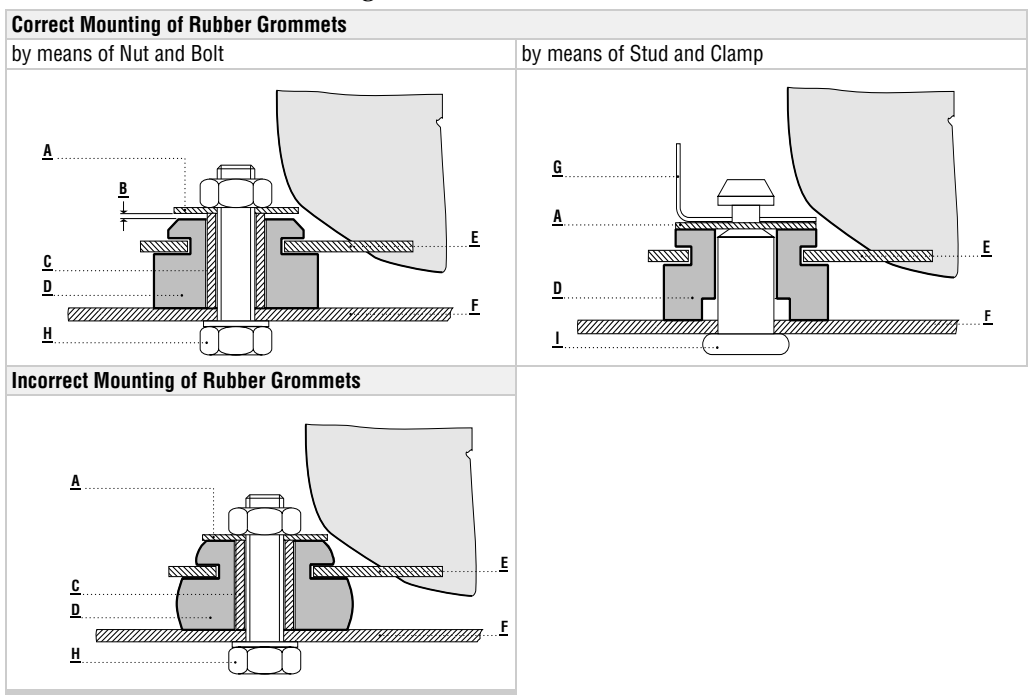
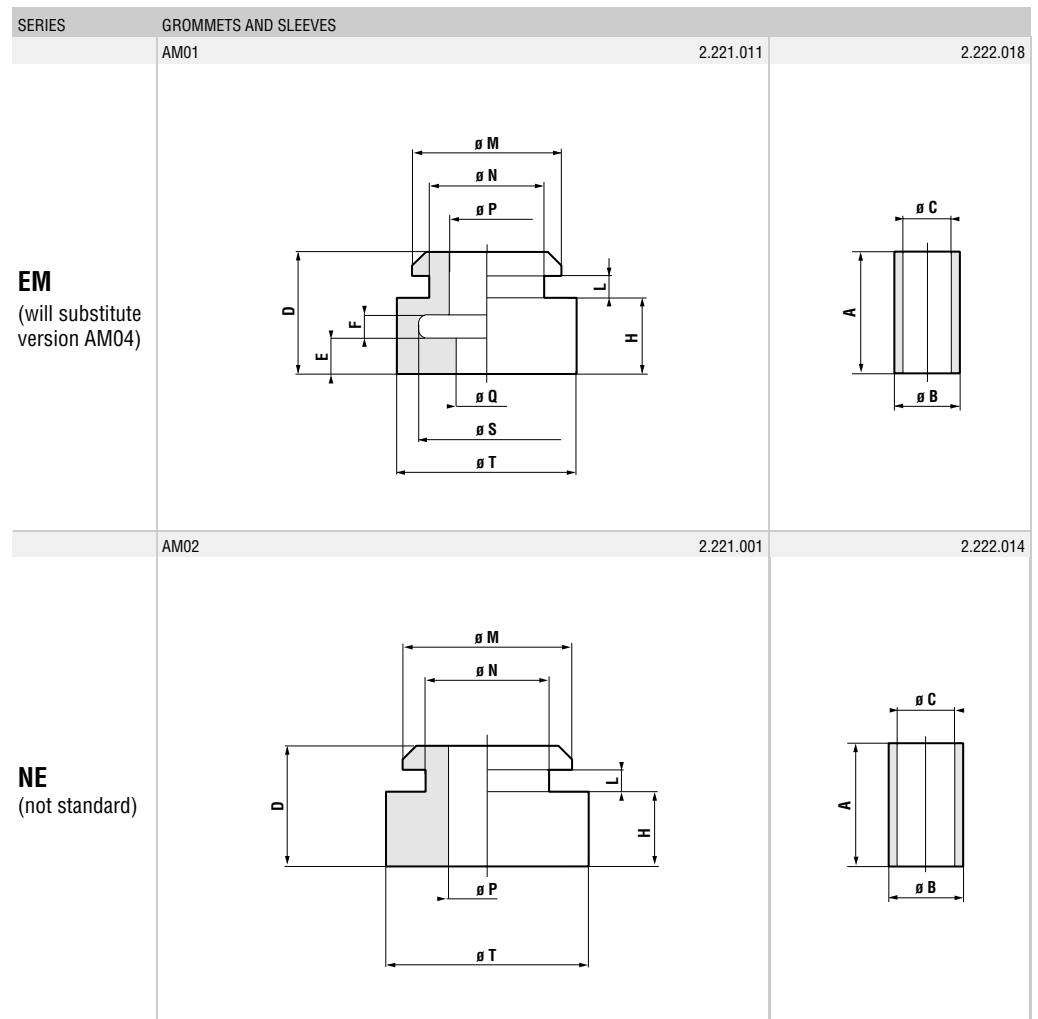



Table 34 **Rubber Grommets**

COD.	A	B	C	D	E	F	G	H	L	M	N	P	Q	R	S	T
AM01	17.2	9	6.6	16.7	5	3		10.5	3	20.8	16	10.5	8.5		19	25
AM02	16.6	11.1	8.7	16.7				10.5	3	23.8	17.5	11.1				28.6
AM03	18.3	11.1	8.7	17.5			4.7	9.5	4	23.8	19	11.1		17.5		31.8
AM04	17.2	9	6.6	16.7	11		3	10.5	3	23.8	16	11	8.5	22		28.6
AM05	23	11.1	8.7	23	9.4	3.2	3.2	15	4	23.8	19	14.3	11.1	19	25.3	31.7

Figure 31 **Rubber Grommets**



SERIES	GROMMETS AND SLEEVES	2.221.003	2.222.015
<b>NB NE</b> Only for models with Universal baseplate	AM03		
	AM04		
	AM05		

## 6.8 WELDING OF CONNECTION TUBES

During brazing of the connectors on the compressor's copper tubes, the following instructions must be observed:

- **DO NOT ALLOW** the flame from the torch to reach the housing during the welding of the compressor tube in order to avoid overheating, damages to welding, and oil carbonization on the compressor's internal walls.
- **DO NOT ALLOW** the flame from the torch to approach the “hermetic terminal” in order to avoid the cracking of the glass insulating material of the three pins and subsequent gas leaks.

The welding of the connections on copper tubes can be done with welding material with low silver contents, or, exclusively for “copper/copper” connections. It can be advantageous to use the “phosphorous copper”.

Proper welding is characterized by a good penetration of weld material, to guarantee a good mechanical resistance, and a lack of leaks from the connection.

These characteristics are obtained with the use of suitable materials and a perfectly performed welding, as well as with a correct sizing of the tubes to be coupled in order to guarantee the optimum clearance. “Tight clearance” determines a bad penetration of weld material, while “large clearance” causes penetration of weld material and de-oxidizers inside the tube and compressor.

To limit the internal contamination by the de-oxidizing flux, we suggest applying small quantities of de-oxidizer on the connection tube after connecting it to the compressor tube.

During the welding operation, avoid overheating of the connection. This reduces the formation of oxide contaminants inside of the tubes. It is suggested, during the welding operation, to blow nitrogen through the tubes, particularly for R404A applications.

With the use of R134a, the possibility of refrigerant gas leaks through defective welds is increased due to the smaller size of the molecule of R134a.

We also suggest taking particular care in performing the welding and leak detection, which must be carried out with equipment sensitive to the refrigerant type used.

## 6.9 ROTALOCK VALVES

For J series compressors, a special version can be supplied only upon the Customer's request. This configuration has, in place of the suction tube, a threaded union welded on the cover of the housing, suitable for fixing a Rotalock suction valve.

A cap screwed on the union guarantees its protection and the internal pressurization of the compressor. This special version can be supplied in two ways:

- Compressor with union for valve but with no Rotalock valve supplied.
- Compressor with union for valve, unassembled Rotalock valve, and equipped with the appropriate sealing gasket.

The threading of the union of 1" - 14 NS-2 accepts Rotalock valves with different dimensions according to the compressor type, as indicated on the Compressor Catalog. The assembly of the valve on the compressor union must be done by inserting the gasket on its seat on the union, after dampening both with a light oil film (of the same type charged into the compressor). The valve nut should be tightened to the torque indicated on the following table. The valve can be oriented, as necessary, within 360°. If necessary it can be easily replaced using a new gasket seal.

In the following table, indicated are the suggested tightening torques:

Table 35 *Suggested tightening torques*

ELEMENT	DIMENSION	TIGHTENING TORQUE	
		Nm	Kgm
Stem opening/closing <sup>(1)</sup>	Valve 1/2" SAE	9.3÷11.3	0.95 ÷ 1.15
	Valve 5/8" SAE	11.3÷13.7	1.15 ÷ 1.40
Fixing nut orientation	Valve 1/2" SAE	67÷82	6.85 ÷ 8.35
	Valve 5/8" SAE	67÷82	6.85 ÷ 8.35
Service nut 1/4"	Valve 1/4" SAE	10.8÷16.3	1.10 ÷ 1.66

(1) The opening and closing of the valve stem can be effected with electric or pneumatic drivers having a speed lower than 360 rpm. Higher speed damages the stem and valve body tightness seats.

For the valves with sweat connections, in order to avoid overheating during welding, which can damage the gasket, we suggest to effect the welding before applying the gasket, and to connect the valve to the compressor.

**It is a good rule to try to keep the welding time to a minimum in order to not overheat the stem tightness, even if produced with material resistant to high temperatures.**

Legend 7 *Rotalock Valve*

- |  |  |
|--|--|
| <ul style="list-style-type: none"> <li><b>1</b> Attachment for service or for a manometer</li> <li><b>2</b> Connection to the receiver or to the compressor</li> <li><b>3</b> Main port</li> <li><b>4</b> Connections for pressure-stat</li> </ul> | <ul style="list-style-type: none"> <li><b>A &amp; B</b> Service caps (hexagonal nuts)</li> </ul> |
|--|--|

Figure 32 *Rotalock Valve*

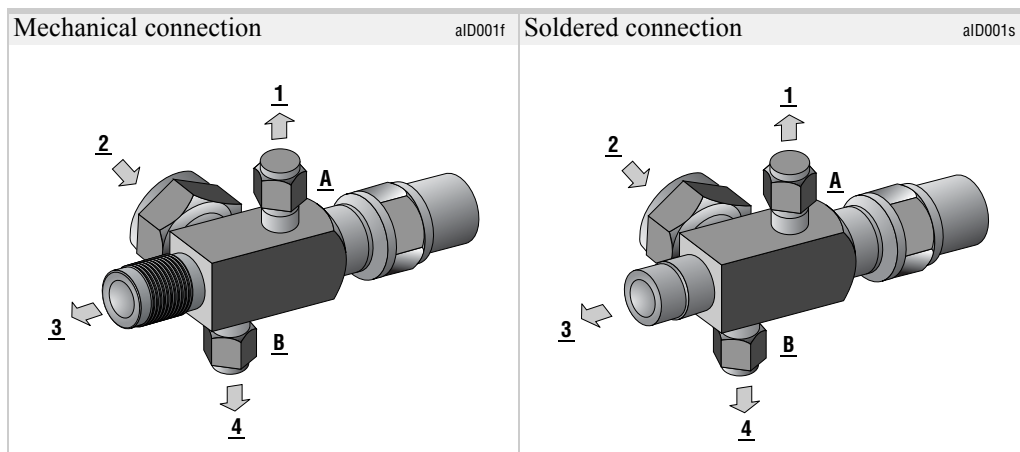
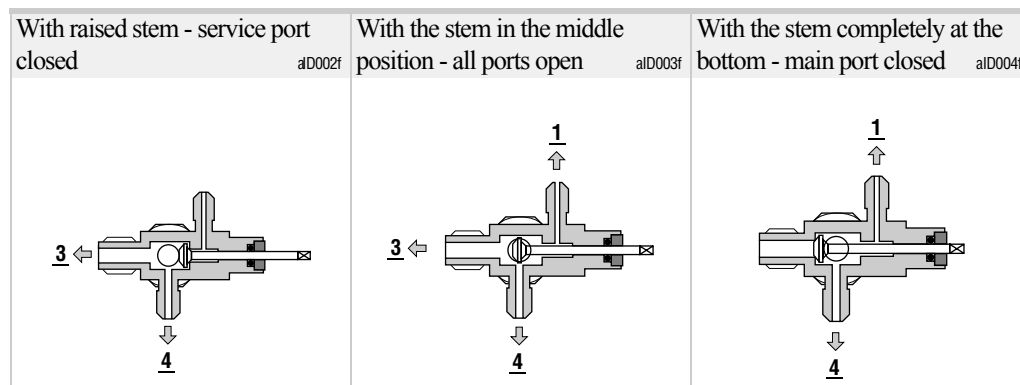

Figure 33 **Valve Position**



## 6.10 COMPRESSOR COOLING

Throughout the Embraco Europe compressor range, there are compressors with different cooling requirements:

- The **static cooling** (without fan cooler) compressor requires that the compressor is positioned in the application in order to be cooled directly by an air current at ambient temperature, through sufficient openings placed in the application body.
- The **fan cooling** compressor requires the use of a fan cooler (normally inlet type) positioned in such a way that the flow is introduced to the compressor sideways (on the longer side opposite to that where it is placed the thermal protector).

The thermal protector, if cooled by the air flow, may not trip, and may not protect the compressor properly.

We suggest to maintain a distance of 0.2 ÷ 0.3 m from compressor fan blades.

The fan cooler can be chosen according to the air flow indicated in Table 36:

Table 36 **Fan Coolers Characteristics**

COMPRESSOR SERIES	NB	EM-NE-T-NT	NJ
FREE AIR FLOW (m <sup>3</sup> /h)	270	520	800

**6.11 VACUUM OPERATIONS**

It is fundamental to perform a proper evacuation of the refrigeration system to ensure proper running of the refrigerating machine, and to preserve the life of the compressor. A proper evacuation process assures that the air and moisture contents are below the allowed limits.

The introduction of new refrigerants require the use of new polyester oils with characteristics of high hygroscopicity which require the greatest care in system evacuation. There are various methods to evacuate a refrigeration system: one-side (low pressure side), two-side (low and high pressure sides), at different times, with phases of refrigerant pre-charge, etc. We must aim to reach a vacuum value (measured at its stabilization on both the low and high pressure sides), better than 0.14 mbar (100  $\mu$ Hg), and the maximum level of non-condensable must not exceed 0.3%.

**PLEASE NOTE:** To avoid irreparable damages to the compressor, never start it under vacuum (without refrigerant charge).

**6.12 REFRIGERANT CHARGE**

After the vacuum operation, the system must be charged with the refrigerant type indicated on the compressor nameplate or one of the alternate allowed types, in the pre-determined quantity.

For a correct charge we suggest, after carrying out the vacuum, to pump part of the refrigerant into the compressor to “break” the vacuum; then start the compressor to draw the remaining part of the charge.

In the small refrigerating systems utilizing few grams of charge, the refrigerant is usually pumped into the compressor through the service tube. In this case you must wait 5 to 10 minutes (time depending on the refrigerant quantity and on the ambient temperature), before starting the compressor. This to allow partial refrigerant evaporation and to avoid the suction of liquid refrigerant into the compressor cylinder.

**PLEASE NOTE:** The refrigerant mixtures must be charged in the system exclusively at liquid state.

Table 37 *Maximum Refrigerant Charge*

SERIES	EM - NE	T	NJ - NT
REFRIGERANT CHARGE (g)	350	500	800

In case the refrigerant charge should exceed the max values allowed for the compressor, take care that the circuit is equipped with liquid receiver, and, for larger systems, an oil heater in the compressor housing to avoid mixing of refrigerant in the oil, foaming with subsequent liquid suction and pumping. If it becomes necessary for a technician to recharge the system in the field, he should first remove all of the remaining original charge, and then recharge the system in accordance with the refrigerant quantity indicated on the data plate.

**PLEASE NOTE:** The use of the compressor outside the intended working range cannot make use of the warranty.

### 6.13 REFRIGERANT LEAKS CONTROL

A refrigeration system can work normally for the entire life of the compressor, only if attention is given to the proper installation. One of the most important aspects is the absence of refrigerant leaks.

We estimate that a 10% leak of the refrigerant charge over 15 years of running the compressor; will still allow for proper running of the refrigerating system.

With the new refrigerants (R134a and mixtures), the possibility of refrigerant leaks through improper welding increase due to the reduced molecular size of the refrigerants. This adds to the increase in the percentage of leaks, due to the reduced charge compared to traditional refrigerants. For above reasons, it is essential that accurate controls of leaks are performed on the welds with methods and equipment suitable to the applied refrigerant type.

**For the leak test of R134a, use equipment designed exclusively for that refrigerant.**

**PLEASE NOTE:** R404A-R402A-R402B refrigerants must not be mixed to the air during leak detection, neither be used nor let in presence of high air concentrations above atmospheric pressure at high temperatures.

### 6.14 ELECTRIC SUPPLY

The compressor assembled in the refrigeration system must be connected to a voltage supply within the limits indicated in Table 5 - Voltages & Frequencies on page 15. Due to voltage drops on the supply circuit, the voltage must be that measured at the compressor hermetic terminal. On the same table, indicated are the minimum starting voltages at which the compressor can start without load. In paragraph 7.1 - COMPRESSOR RUNNING LIMITS - 7.1.6 - Start conditions - are indicated, for compressor start, the limit values of suction pressure, discharge pressure and supply voltage.

The correct sizing of the cables is important to guarantee low voltage drops on running and during the phases of compressor start, and it must be determined according to the locked rotor current indicated on the "ElectricComponents List". A subsequent protection fuse can also be sized:

- 225% of the compressor running current plus 100% of current input of all other electric motors employed.
- For three-phase models, use remote control, so sized switches that each contactor can withstand the current input value of compressor.

**PLEASE NOTE:** The electrical wiring must be performed according to the laws and regulations in the country in which the refrigeration system will operate.

# 7      **RUNNING DATA AND COMPRESSOR CHECKING PROCEDURES**

## 7.1      **COMPRESSOR RUNNING LIMITS**

The sizing of the system components must be performed in a way that the limits of the characteristics indicated below are not exceeded. During operation in the field, the system can encounter some factors worsening the working conditions, such as gas leaks, reduction of the effectiveness on the condenser due to clogging, etc. Because of these factors, it is recommended to size the system with a good margin of safety, to allow the system to operate within the prescribed limits.

### 7.1.1      **Maximum temperature of electric motor stator windings**

- 130 °C max, under normal running conditions.

The temperature measurement can be done while the compressor is running through compatible equipment (for inst. SILYTESTER of BIDDLE USA), or through the method of ohmic resistance measurement, by disconnecting the compressor supply.

This method requires the availability of instruments for measuring the ohmic resistance (digital Ohmmeter, Wheatstone's bridge) and the temperature.

- a) Measure the ohmic resistance  $R_f$  of the main winding (run) between the pins of the hermetic terminal C “common” (above) and R “run” (below on the right) and of the corresponding stabilized reference temperature  $T_f$ .
- b) Measure the ohmic resistance  $R_c$  of the main winding (run) with hot motor between the pins C and R at the  $T_c$  temperature to calculate.
- c) Calculate the  $T_c$  temperature with the following formula:

$$T_c = \frac{(R_c - R_f)}{R_f} (234,5 + T_f) + T_f$$

Where:

Legend 8

- T<sub>c</sub>** = Unknown temperature with hot motor
- T<sub>f</sub>** = Motor temperature measured at the stabilized reference temperature
- R<sub>c</sub>** = Measured ohmic resistance, corresponding to the **T<sub>c</sub>** temperature
- R<sub>f</sub>** = Measured ohmic resistance, corresponding to the **T<sub>f</sub>** temperature



**7.1.2 Discharge gas maximum temperature**

- Maximum temperature indicated in Table 38, measured on discharge tube at a distance of 50mm from compressor housing, under continuous running conditions.

**7.1.3 Discharge gas maximum pressures**

- Pressure max peak, under “Pull-down”, as indicated in Table 38.
- Maximum pressures, under continuous running, as indicated in Table 38.

 Table 38 *Discharge gas maximum pressures*

Refrigerant	PULL-DOWN MAXIMUM PEAK		MAXIMUM VALUE CONDITION		MAX. TEMP. DISCHARGE GAS
	kg/cm <sup>2</sup> (rel.)	bar (rel.)	kg/cm <sup>2</sup> (rel.)	bar (rel.)	°C
R22	23.2	22.8	20.7	20.3	125
R290 (Propane)	21.1	19.8	18.1	17.7	110
R134a	15.8	15.5	13.9	13.6	140
R600a (Isobutane)	7.7	7.5	6.7	6.6	110
R407C	24.2	23.8	21.4	21.0	140
R404A	27.7	27.2	24.7	24.2	140
R507	28.5	27.9	25.4	24.9	140

- Make sure that at the maximum ambient temperature anticipated the compressor operates within the operating field indicated in the following section.

**7.1.4 Suction gas overheating**

- Maintain the suction gas temperature overheating as low as possible (min 5 °C), taking care that there is no return of liquid.
- Length of heat exchanger from 0.9 m to 1.3 m.

### 7.1.5 Compressor operating fields

- Within the minimum and maximum values typical for each model.

In the diagrams represented on the following pages, indicated are the limits of evaporating, condensing, ambient and return gas temperatures.

The compressor can operate within the limits of evaporating and condensing temperatures defined by the outlined area bordered by a continuous line, at the indicated conditions of ambient and return gas temperature.

Outside these operating fields, the system operates at high pressures and high temperatures, and cause early defects in the compressor.

The compressor defects caused by applications operating outside the prescribed fields will not be considered under warranty.

#### 7.1.5.1 R22 Compressors operating field

The production of R22 compressors was required for the replacement of R12 - R502 refrigerants and the choice has been obliged by the non availability at that moment of other suitable alternative gases.

For low and medium temperature R22 cabinets, compressors must be selected according to the limits associated with this type of gas, that was developed for high evaporating temperatures, thus characterized by restrictive limits.

#### 7.1.5.2 R404A - R507 - R600a - R134a - R22 – R290 compressors operating field

The working fields represented in this section are related to all model and series of compressors that take the indicated refrigerant.

- 1 – LBP: R134a – R600a
- 2 – LBP: R404A – R507 – R290
- 3 – MBP: R404A – R507 – R290
- 4 – HBP: R134a – R600a – R 22
- 5 – LBP: R 22
- 6 – AC

Legend 9

**T<sub>c</sub>** Condensing Temperature  
**T<sub>e</sub>** Evaporating Temperature

**k** Ambient 32 °C and return gas 20 °C  
**m** Ambient 32 °C and return gas 20 °C  
(for a transitory period)

1 - REFRIGERANT R134a - R600a - APPLICATION LBP

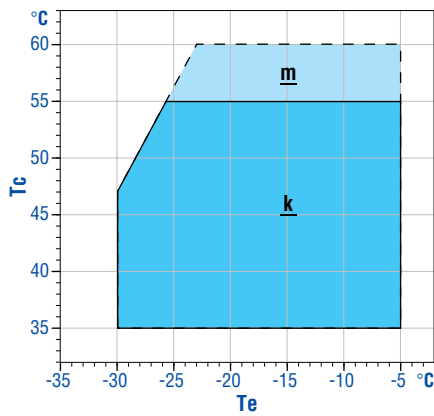

2 - REFRIGERANT R404A - R507 - R290 - APPLICATION LBP

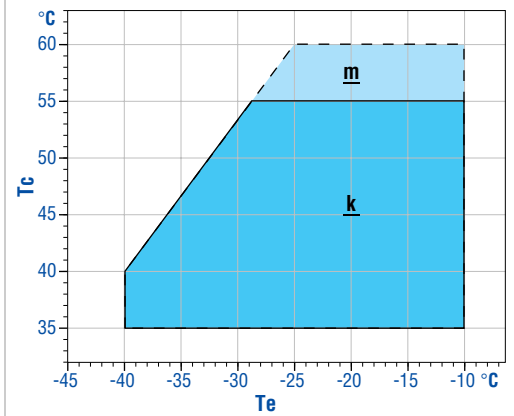

3 - REFRIGERANT R404A - R507 - R290 - APPLICATION MBP

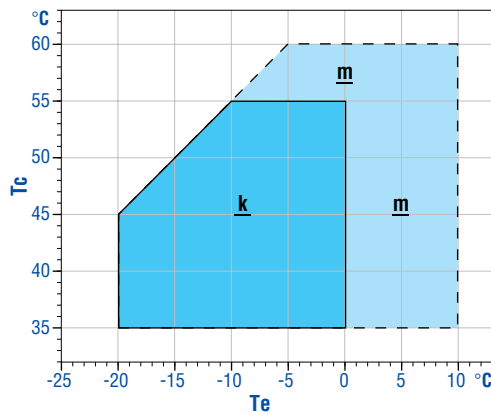

4 - REFRIGERANT R134a - R600a - R22 - APPLICATION HBP

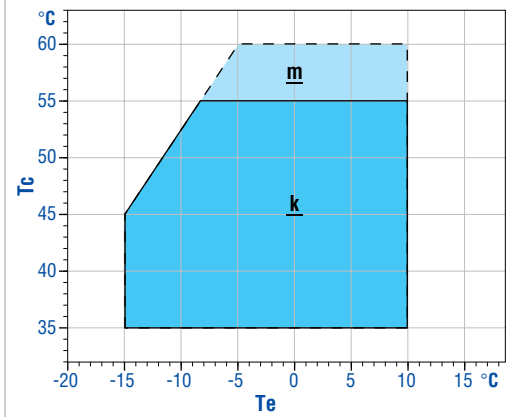

3 - REFRIGERANT R22 - APPLICATION LBP

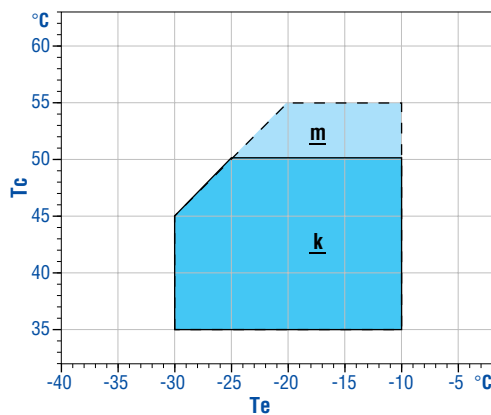

4 - APPLICATION AC

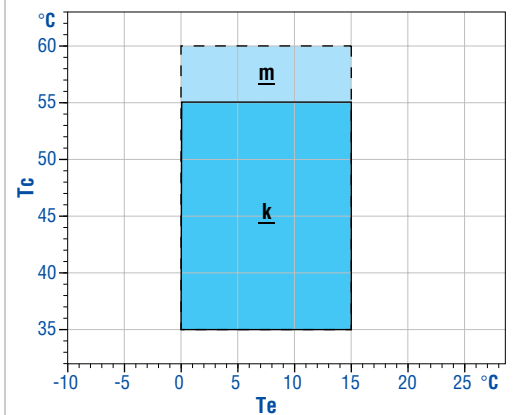

**7.1.6 Start conditions**

- On Table 39, indicated are the pressure limits to start the compressor at nominal or higher voltage than 90% of rated values. (Equal or higher than 85% of rated value for AC models). For applications where the pressure and voltage are outside the indicated limits, compressor start is not guaranteed.

Table 39 *Pressure limit value*

APPLICATION TYPE	STARTING TORQUE TYPE	REFRIGERANT TYPE	GAUGE PRESSURE			
			SUCTION		DISCHARGE	
			Kg/cm <sup>2</sup>	bar	Kg/cm <sup>2</sup>	bar
LBP	LST	R134a	5.1	5.0	5.1	5.0
		R 600a	2.2	2.1	2.2	2.1
		R 22	8.6	8.4	8.6	8.4
		R404A	10.5	10.3	10.5	10.3
		R507	10.9	10.7	10.9	10.7
	R290	7.8	7.4	7.8	7.4	
	HST	R134a	1.0	1.0	12.2	11.9
		R600a	0.1	0.1	5.8	5.7
		R22	2.5	2.5	18.4	18.1
		R404A	3.3	3.3	22.0	21.5
R507		3.5	3.4	22.6	22.2	
MBP HBP	LST	R290	2.4	2.4	16.1	15.8
		R134a	12.5	12.3	12.5	12.3
		R600a	2.7	2.6	2.7	2.6
		R 22	10.0	9.8	10.0	9.8
		R404A	12.1	11.9	12.1	11.9
	HST	R507	12.5	12.3	12.5	12.3
		R290	9.0	8.8	9.0	8.8
		R134a	2.9	2.8	13.9	13.6
		R600a	1.0	1.0	6.7	6.6
		R22	5.4	5.3	20.7	20.3
AC	HST/LST	R404A	6.7	6.6	24.7	24.3
		R507	7.0	6.9	25.4	24.9
		R290	5.0	4.9	18.1	17.7
		R 22	10.9	10.7	10.9	10.7
		R407C	10.7	10.5	10.7	10.5

**PLEASE NOTE:** In order to avoid irreparable damages to the compressor, never apply voltage when the system is under vacuum.

**7.1.7 Oil cooler temperatures**

- Equal inlet and outlet gas temperatures or with a maximum difference of 3 °C.
- We suggest to connect the condenser to the oil cooler at 1/3 of its total length (the final 2/3 of condenser after oil cooler).

**7.1.8 Running time**

- Size the systems for max 80% of normal running time.
- 100%, under heavy load and ambient temperature conditions.

**7.1.9 Cycling**

- The systems must be sized for max 5 cycles / hour (average cycling).
- Compressors with PTC starting devices must be re-started after a minimum time of 5 minutes from their off cycle.
- The trip of thermal /current protection requires that the compressor re-start occurs after the necessary time for the protector to reset.

---

**7.2 COMPRESSOR CONTROL PROCEDURES**

The operational failures that may happen to the refrigeration system can be, in most cases, identified and eliminated by consulting Table 40 - Troubleshooting and service chart.

The diagnostic control for identification of the defected component or the electrical failure in the circuit can be handled by following the steps listed in the chapter 7.4 - ELECTRIC CIRCUITS CONTROL.

---

**7.3 TROUBLESHOOTING AND SERVICE CHART**

This list offers the possibility to quickly identify, according to the apparent defect, the possible causes and the subsequent repairs to be made.

The listed defects are among the most common to be found in established applications. For other possible defects which do not appear in the list or for running problems in the design phase of the application, please contact Embraco Europe Technicians in the Sales Department.

Table 40 *Troubleshooting and service chart*

PROBLEM	POSSIBLE CAUSE	REPAIR
1 Compressor will not start - No hum.	1.1 Line disconnected. Starting relay open	Check the line and the starting relay contacts.
	1.2 Fuse removed or blown.	Replace the fuse.
	1.3 Overload protector tripping.	Check the electrical connections.
	1.4 Pressure-switch in open position.	Replace the Pressure-switch.
	1.5 Thermostat not correctly adjusted.	Reset or replace the thermostat.
	1.6 Electrical connections improper or loose.	Check wiring against diagram, or tighten the connections.
2 Compressor will not start (hums) but trip on the overload protector.	2.1 Improperly wired.	Check wiring against diagram. Redo the electrical connections according to the electrical diagram.
	2.2 Low voltage at the compressor.	Determine reason and correct.
	2.3 Start capacitor defective.	Determine reason and replace the capacitor if necessary.
	2.4 Relay failing to close.	Determine reason and correct, replace the relay if necessary.
	2.5 Compressor motor has a winding open or shorted.	Replace the compressor.
	2.6 Internal mechanical problem in compressor.	Replace the compressor.
3 Compressor starts, but does not switch off of start winding.	3.1 Improperly wired.	Check wiring against diagram.
	3.2 Low voltage at the compressor.	Determine reason and correct.
	3.3 Run capacitor defective.	Determine reason and replace.
	3.4 Relay failing to open.	Determine reason and correct, replace if necessary.
	3.5 Excessively high discharge pressure.	Check discharge shut-off valve, possible overcharge, or insufficient cooling at condenser.
	3.6 Compressor motor has a winding open or shorted.	Replace the compressor.
	3.7 Internal mechanical problem in compressor (tight).	Replace the compressor.
4 Compressor starts and runs, but short cycles on overload protector.	4.1 Additional current passing through overload protector.	Check wiring diagram. Check for added fan motors, pump, etc. connected to the wrong side of protector.
	4.2 Low voltage at compressor (or unbalanced if three phase).	Determine reason and correct.
	4.3 Overload protector defective.	Check current, replace protector.
	4.4 Run capacitor defective.	Determine reason and replace.
	4.5 Excessively high discharge pressure.	Check ventilation, restrictions in cooling medium, restriction in refrigeration system.
	4.6 Excessively high suction pressure.	Check for possibility of incorrect application. Use stronger unit.
	4.7 Compressor too hot. Return gas hot.	Check refrigerant charge, repair leaks, and add gas if necessary.
	4.8 Compressor motor has a winding shorted	Replace the compressor.

PROBLEM	POSSIBLE CAUSE	REPAIR
5 Unit runs OK but short cycles on.	5.1 Overload protector.	See section 4.
	5.2 Thermostat.	Differential set too close. Widen.
	5.3 High pressure cut-out due to insufficient air or water supply.	Check and correct air or water supply to condenser.
	5.4 High pressure cut-out due to gas overcharge.	Reduce the refrigerant charge.
	5.5 High pressure cut-out due to air in the system.	Repeat vacuum and refrigerant charge.
	5.6 Low pressure cut-out due to liquid line solenoid leaking.	Replace solenoid valve.
	5.7 Low pressure cut-out due to compressor valve leak.	Replace valve.
	5.8 Low pressure cut-out due to gas undercharge.	Repair leak and add refrigerant.
	5.9 Low pressure cut-out due to restriction in expansion valve.	Replace the expansion valve.
6 Unit operates long or continuously.	6.1 Low refrigerant charge.	Repair leak and add charge.
	6.2 Control contacts stuck or frozen closed.	Clean contacts or replace control.
	6.3 Refrigerated or air conditioned space has excessive load or poor insulation.	Determine fault and correct.
	6.4 System inadequate to handle load.	Replace with larger system.
	6.5 Evaporator coil iced.	Defrost.
	6.6 Restriction in refrigeration system.	Determine location and remove.
	6.7 Dirty condenser.	Clean condenser.
	6.8 Dirty filter.	Clean or replace.
7 Start capacitor open, shorted or blown.	7.1 Relay contacts not operating properly.	Clean contacts or replace relay if necessary.
	7.2 Prolonged operation on start cycle due to low voltage to unit.	Determine reason and correct.
	7.3 Prolonged operation on start cycle due to improperly relay.	Replace the starting relay.
	7.4 Prolonged operation on start cycle due to starting load too high.	Correct by using pump down arrangement if necessary.
	7.5 Excessive short cycling.	Determine reason for short cycling (see section 5) and correct.
	7.6 Improper start capacitor.	Determine correct size and replace.
8 Run capacitor open, shorted or blown.	8.1 Improper run capacitor.	Determine correct size and replace.
	8.2 Excessively high line voltage (out of the allowable limit).	Determine reason and correct.
9 Relay defective or burned out.	9.1 Incorrect starting relay.	Check and replace.
	9.2 Incorrect mounting angle.	Remount relay in correct position.
	9.3 Line voltage too high or too low.	Determine reason and correct.
	9.4 Excessive short cycle.	Determine reason (see section 5) and correct.
	9.5 Relay being influenced by loose vibrating, mounting.	Remount tightly.
	9.6 Incorrect run capacitor.	Replace with proper capacitor.
10 Space temperature too high.	10.1 Control setting too high.	Reset control.
	10.2 Expansion valve too small.	Use larger valve.
	10.3 Cooling coils too small.	Add surface or replace.
	10.4 Inadequate air circulation.	Improve air movement.

<b>PROBLEM</b>	<b>POSSIBLE CAUSE</b>	<b>REPAIR</b>
11 Suction line frosted or sweating.	11.1 Expansion valve passing excess refrigerant or is oversized.	Readjust valve or replace with smaller valve.
	11.2 Expansion valve stuck open.	Clean valve of foreign particles, replace if necessary.
	11.3 Evaporator fan-motor not running.	Determine reason and correct.
	11.4 Overcharge of refrigerant.	Correct charge.
12 Liquid line frosted or sweating.	12.1 Restriction in drier or strainer.	Replace part.
	12.2 Liquid shut-off (main valve) partially closed.	Open valve fully.
13 Unit noisy.	13.1 Loose parts or mountings.	Locate and tighten.
	13.2 Rubber grommets mounted without sleeves or in correctly assembled.	Add the sleeves or mount correctly.
	13.3 Tubing rattle.	Reform to be free of contact.
	13.4 Bent fan blade causing vibration.	Replace fan.
	13.5 Fan motor bearing worn.	Replace fan-motor.
	13.6 Tubes joint incorrect (gas noise).	Reconnect joint correctly.



## 7.4 ELECTRIC CIRCUITS CONTROL

The electric tests reported in this chapter allow to determine the causes of possible anomalies or defects of electric components, electric motor and wiring for each type of electric motor. In case the problems appear during the final testing of the refrigerating application, before starting the check procedures, it is better to be sure that the connections are correct according to the electric wiring diagrams represented in Chapter 2.9. To carry out the check, it is necessary to use suitable instruments for checking the continuity and for measuring the ohmic resistance, respecting the indicated sequence and referring to the electric diagrams (see chapter 2.9). Consider that the continuous lines represent the leads belonging to the electric component, or to the supplied wiring, while the dashed lines represent the suggested connection leads pertaining to the customer.

**PLEASE NOTE:** Wiring carried out differently from the ones indicated on the Compressor Handbook may require a different check procedure and measurement from the one indicated.

### 7.4.1 Standard version RSIR - RSCR EM Series with PTC starting device

*(Refer to the **RSIR** and **RSCR** electric diagrams represented in Figure 9, page 24)*

Verify, with a voltmeter, the presence of the correct voltage on the “L2” and “N” terminals of the terminal board. If there is insufficient voltage, the thermostat is defective due to open contacts, connections or an interruption in the cables.

Disconnect the other electrical components if present (motor fan, gear motor, etc.), disconnect the voltage to the circuit at the supply line, and carry out the following operations and checks:

1. Check the continuity on the terminals L1 - L2 of the terminal board. If there is no continuity, the thermostat must be replaced due to open contacts.
2. Take off the PTC starting device from the hermetic terminal.
3. If there is a capacitor (RSCR version), disconnect it.
4. Take off the protector from the PTC starting device and check between points 1 and 3. If there is no continuity, be sure that the protector has no open contacts due to its trip. In this case repeat the check after about 10 minutes. Otherwise, the protector is defective due to open contacts.
5. Check the electric motor according to the procedure described at par. 7.5.1.
6. Check the ohmic resistance of the stator run and start windings according to the procedure described in par. 7.5.2.
7. On the PTC starting device, check between the two fastons “1” and “3” the ohmic resistance of the PTC pill which must be  $8 \div 16 \frac{3}{4}$  for the 230V model and  $2 \div 4 \frac{3}{4}$  for the 115V model, at the ambient temperature of 25 °C. (CAUTION: the ohmic resistance values measured with a normal tester can be out of the indicated values by as much as 25% ÷ 30%).
8. If there is a run capacitor (RSCR version), check it according to the procedure described in section 7.5.3.

If from all the above checks no problem was found, there is no capillary clogging and the system does not yet run correctly, replace the compressor.

### 7.4.2 **Standard version RSIR - RSCR EM Series with PTC starting device**

*(Refer to the RSIR e RSCR electric diagrams represented on Figure 10, page 24)*

Verify with a voltmeter the presence of the correct voltage on the “L” and “N” terminals of the PTC starting device. If there is insufficient voltage, the thermostat is defective due to open contacts, connections, or an interruption in the cables.

Disconnect the other electrical components if present (motor fan, gear motor, etc.), disconnect the voltage to the circuit at the supply line, and carry out the following operations and checks:

1. Check the continuity on the terminals L3 of PTC starting device. If continuity lack,s the thermostat must be replaced due to open contacts.
2. Take off the PTC starting device from the hermetic terminal.
3. If there is a run capacitor (RSCR version) disconnect it.
4. Take off the protector from the PTC starting device and check between points 1 and 3. If there is no continuity, be sure that the protector has no open contacts due to its trip. In this case, repeat the check after about 10 minutes. Otherwise, the protector is defective due to open contacts.
5. Check the electric motor according to the procedure described in par.7.5.1.
6. Check the ohmic resistance of the stator run and start windings according to the procedure described in par.7.5.2.
7. On the PTC starting device check between the two fastons N and 2, the ohmic resistance of the PTC pill which must be  $8 \div 16 \square$  for the 230V model and  $2 \div 4 \square$  for the 115V model, at the ambient temperature of 25 °C. (CAUTION: the ohmic resistance values measured with a normal tester can be out of the indicated by as much as 25% ÷ 30%).
8. If there is a run capacitor (RSCR version), check it according to the procedure described in section 7.5.3.

If from all the above checks no problem was found, there is no capillary clogging and the system does not yet run correctly, replace the compressor.

### 7.4.3 **Standard version RSIR NB - NE - NT - T Series with electromagnetic current relay**

*(Refer to the RSIR electric diagram represented in Figure 11, page 25)*

**PLEASE NOTE:** The contacts of the starting relay are normally open.

Verify with a voltmeter the presence of the correct voltage on terminals “1” of relay and “3” of protector. If there is insufficient voltage, the thermostat is defective due to open contacts, connections, or there is an interruption in the cables.

Disconnect the other electric components if present (motor fan, gear motor, etc.), disconnect the voltage to the circuit at the supply line, and carry out the following operations and checks:

1. Check the continuity between the points “1” - “3” of protector: If there is no continuity, be sure that the protector has no open contacts due to its trip. In this case, repeat the check after about 10 minutes.
2. Take off the start relay from the hermetic terminal and keeping it in the same vertical position, (do not incline or overturn) carry out the following continuity checks.
3. Between the terminals “1” and “S” on the relay: If there no continuity the relay is faulty due to closed contacts.

4. Between the terminals “1” and “R” of relay: If there is no continuity the relay has an open coil.
5. Check the electric motor according to the procedure described in par. 7.5.1.
6. Check the ohmic resistance of the stator run and start windings according to the procedure described in par. 7.5.2.

If from all above checks, no problem was found, there is no capillary clogging, and the system does not yet run correctly, replace the starting relay, excluding possible faults of contacts opening and closing (pick-up and drop-out current) that can not to be determined with above checks.

If the compressor does not yet run correctly, it must be replaced due to internal defects.

#### 7.4.4 **Standard version CSIR NB - NE - NT Series with electromagnetic current relay**

*(Refer to the electric diagram CSIR represented in Figure 11, page 25)*

**PLEASE NOTE:** The contacts of starting relay are normally open.

Verify with a voltmeter the presence of the correct voltage on the terminals 2 of relay and 3 of protector. If there is insufficient voltage, the thermostat is defective due to open contacts, connections, or there is an interruption in the cables. Disconnect the other electric components if present (motor fan, gear motor, etc.), disconnect the voltage to the circuit at the supply line and carry out the following operations and checks:

1. Check the continuity between the points 1 and 3 of the protector. If continuity lacks, be sure that the protector has no open contacts due to its trip. In this case repeat the check after about 10 minutes.
2. Take off the start relay from the hermetic terminal and keep it in the same vertical position (do not incline or overturn). Carry out the following continuity checks:
3. Between the terminals 1 and S on the relay: if there is continuity the relay is faulty due to closed contacts.
4. Between the terminals 2 and R of relay: if there is no continuity the relay coil is open.
5. Check the electric motor according to the procedure described in section 7.5.1.
6. Check the ohmic resistance of the stator run and start windings according to the procedure described on section 7.5.2.
7. Check the start capacitor according to the procedure indicated on section 7.5.3.

If from all the above checks, a problem was not found, there is no clogging in the expansion device and the system does not yet run correctly, replace the starting relay, excluding possible faults of the contacts opening and closing (pick-up and drop-out currents) that can not be determined with above checks.

If the compressor does not yet run correctly, it must be replaced due to internal defects.

**7.4.5 Terminal board version RSIR NB - NE - T Series with electromagnetic current relay**

*(For T Series, refer to the **RSIR** electric diagram represented in Figure 12, page 25)*

*(For NB-NE Series, refer to the **RSIR** electric diagram represented in Figure 13, page 26)*

**PLEASE NOTE:** The contacts of the starting relay are normally open.

Verify with a voltmeter the presence of the correct voltage on the terminals “1” and “N” of the terminal board. If there is insufficient voltage, the thermostat is defective due to open contacts, connections, or there is an interruption in the cables.

Disconnect the other electric components if present (motor fan, gear motor, etc.), disconnect the voltage to the circuit at the supply line and carry out the following operations and checks:

1. Remove the terminal board, take off the starting relay and disconnect the protector cable from the hermetic terminal.
2. Protector: Check the continuity between the points “1” of protector, and “1” of terminal board. If there is no continuity, the protector can be:
  - faulty due to open contacts
  - tripped; then repeat the check after about 10 minutes
  - not connected to the terminal board.
3. Keep the start relay in the same vertical position as assembled on the hermetic terminal (do not incline or overturn), and carry out the following continuity checks:
4. Between the terminals “N” on the terminal board and “S” on the relay: if there is continuity the relay is defective due to closed contacts.
5. Between the terminals “N” on the terminal board and “R” of relay: if there is no continuity, the defect can be due to:
  - relay with open coil
  - relay not connected to the terminal board.
6. Check the electric motor according to the procedure described on section 7.5.1.
7. Check the ohmic resistance of the stator run and start windings according to the procedure described in section 7.5.2.

If from all above checks, a problem was not found, there is no capillary clogging, and the system does not yet run correctly, replace the starting relay, excluding possible faults of contacts opening and closing (pick-up and drop-out currents) that can not be determined with above checks.

If the compressor does not yet run correctly, it must be replaced due to internal defects.

**7.4.6 Terminal board version CSIR NB - NE - NT - T Series with electromagnetic current relay**

*(For T Series, refer to the electric diagram **CSIR** represented on Figure 12, page 25)*

*(For NB-NE Series, refer to the electric diagram **CSIR** represented on Figure 13, page 26)*

**PLEASE NOTE:** The contacts of starting relay are normally open.

Disconnect the other electric components if present (motor fan, gear motor, etc.), disconnect voltage to the circuit at the supply line, and carry out the following operations and checks:

1. Remove the terminal board, take off the start relay and disconnect the protector cable from the hermetic terminal.
2. Protector: check the continuity between the points “1” of protector, and “1” of terminal board. If there is no continuity, the protector can be:
  - faulty due to open contacts
  - tripped; then repeat the check after about 10 minutes
  - not connected to the terminal board.
3. Keeping the starting relay in the same vertical position as assembled on the hermetic terminal (do not incline or overturn), carry out the following continuity checks.
4. Between the terminals N on the terminal board and R of relay: if there is no continuity, the defect can be due to:
  - relay with coil breaking
  - relay not connected to the terminal board.
5. Between the terminals 1 and S of relay: if there is continuity, the relay is faulty due to closed contacts.
6. Check the electric motor according to the procedure described in par. 7.5.1.
7. Check the ohmic resistance of the stator run and starting windings according to the procedure described in par. 7.5.2.
8. Check the starting capacitor according to the procedure indicated in par. 7.5.3.

If from all above checks no problem was found, there are no clogging in the expansion device and the system does not yet run correctly, replace the starting relay, excluding possible faults of contacts opening and closing (pick-up and drop-out currents) that can not be determined with above checks.

If the compressor does not yet run correctly, it must be replaced due to internal defects.

#### **7.4.7 Terminal board version RSIR and RSCR NB Series with PTC starting device**

*(Refer to the electric diagrams **RSIR** and **RSCR PTC** represented on Figure 14, page 26)*

Disconnect electrically, other electric components if present (motor fan, gear motor, etc.), interrupt the voltage to the circuit disconnecting it from the supply line, and carry out the following operations and checks:

1. Remove the terminal board, take off the PTC starting device from the hermetic terminal and disconnect the protector lead from the hermetic terminal.
2. Check on the protector the continuity between the points 1 of protector and 1 of terminal board. If continuity lacks the protector can be:
  - faulty for open contacts
  - tripped, then repeat the check after about 10 minutes
  - not connected to the terminal board.
3. Check, on the PTC starting device, the continuity between the points of PTC starting device and N of terminal board. If continuity lacks check the lead and its connections.
4. If there is a run capacitor (RSCR version), disconnect it.
5. Check the electric motor according to the procedure described in section 7.5.1.
6. Check the ohmic resistance of the stator run and start windings according to the procedure described in section 7.5.2.

7. On PTC starting device check, between the two faston terminals 1 and 3 the ohmic resistance of the PTC pill which must be  $8 \div 16$  for the model at 230V and  $2 \div 4$  for the model at 115V, at the ambient temperature of 25 °C.
8. If there is the run capacitor (RSCR version), check it according to the procedure described in par. 7.5.3.

If from all the above checks, no problem was found, there is no capillary clogging and the system does not yet run correctly, replace the compressor.

#### 7.4.8 **Standard version PSC NE - NT - NJ Series**

*(Refer to the electric diagrams PSC represented on Figure 15, page 27)*

Verify with a voltmeter the presence of the correct voltage between the terminals R and C of the hermetic terminal (version with internal protector), or between R on hermetic terminal, and 1 on external overload protector. If there is insufficient voltage, the thermostat is faulty due to open contacts or there is an interruption on the cables or on the connections.

Disconnect the other electric components if present (motor fan, gear motor, etc.), interrupt voltage to the circuit atom the supply line, and carry out the following operations and checks:

1. If there is an external overload protector, check the continuity between points 1 and 3. If there is no continuity, the protector can be faulty, or there could have been a trip, so repeat the check after about 10 minutes.
2. Check the electric motor according to the procedure described in section 7.5.1.
3. Check the ohmic resistance of the stator run and start windings according to the procedure described in section 7.5.2.
4. Check the run capacitor according to the procedure indicated in section 7.5.3.

If from all above checks, no problem was found, there are no clogging in the expansion device, and the system does not yet run correctly, replace the compressor.

#### 7.4.9 **Standard versions CSR - CSR BOX NE - NT - NJ Series with potential current relay**

*(Refer to the electric diagrams CSR represented in Figure 15, page 27)*

*(Refer to the electric diagrams CSR BOX represented in Figure 16, page 27)*

Verify with a voltmeter the presence of the correct voltage on the terminals 4 and 5 of the starting relay. If there is insufficient voltage, the thermostat is faulty due to open contacts, connections, or there is an interruption in the cables.

Disconnect the other electric components if present (motor fan, gear motor, etc.), interrupt the voltage to the circuit disconnecting it from the supply line and carry out the following operations and checks:

1. Disconnect all the connections on terminals 2 and 5 of the starting relay.
2. Check the continuity between terminals 2 and 5 of the starting relay. If there is no continuity, there is a broken coil and the relay must be replaced.
3. Check the continuity between the terminals 1 and 2 of the starting relay. If there is no continuity, the contact is open and the relay must be replaced.
4. If there is an external overload protector, check, according to the type, the continuity between the terminals 1 and 3 or 1 and 2. If there is no continuity, the protector can be faulty or there could have been a trip, so repeat the check after about 10 minutes.

5. Check the electric motor according to the procedure described in section 7.5.1.
6. Check the ohmic resistance of the stator run and start windings according to the procedure described in section 7.5.2.
7. Disconnect one of the two cables of the starting capacitor.
8. Check the start and run capacitors according to the procedure described in section 7.5.3.
9. Check the continuity of the cables disconnected from the 2 and 5 terminals of the starting relay.

If from all above checks, no problem was found, there is no clogging in the expansion device, and the system does not yet run correctly, replace the starting relay, excluding possible mistakes of opening and closing of the contacts (pick-up and drop-out currents) that can not be found with above checks.

If the compressor does not yet run correctly, it must be replaced due to internal defects.

#### 7.4.10 **Standard versions CSIR and CSIR BOX NT and NJ Series with current electromagnetic relay**

*(Refer to electric diagrams CSIR represented on Figure 17, page 28)*

*(Refer to electric diagrams CSIR BOX represented on Figure 18, page 28)*

**PLEASE NOTE:** The contacts of the starting relay are normally open.

Verify with a voltmeter the presence of the correct net voltage on the terminals 3 and 5 of the starting relay. If there is insufficient voltage, the thermostat is defective due to open contacts, connections, or there is a break in the cables.

Disconnect the other electric components, if present (motor fan, gear-motor, etc.), interrupt the voltage to the circuit at the supply line, and carry out the following operations and checks:

1. Disconnect all connections on terminal 3 of the starting relay.
2. Keeping the start relay in the same vertical position as assembled on the hermetic terminal (do not incline or overturn), carry out the following continuity checks:
3. Check the continuity between the terminals 3 and 4 of the starting relay. If there is no continuity, the coil is interrupted and the relay must be replaced.
4. Check the continuity between the terminals 1 and 2 of the starting relay. If there is continuity, the contact is closed and the relay must be replaced.
5. Check the protector continuity between points 1 and 3. If there is no continuity, the protector can be:
  - defective
  - tripped; then repeat the check after about 10 minutes.
6. Check the electric motor according to the procedure described in section 7.5.1.
7. Check the ohmic resistance of the stator start and run windings according to the procedure described in section 7.5.2.
8. Check the start capacitor according to the procedure indicated in section 7.5.3.
9. Check the continuity of the cables disconnected from terminal 3 of the start relay.

If from all above checks, no problem was found, there is no clogging in the expansion device, and the system does not yet run correctly, replace the starting relay, excluding possible mistakes of opening and closing of the contacts (pick-up and drop-out currents) that can not be found with

above checks.

If the compressor does not yet run correctly it must be replaced due to an internal defects.

#### 7.4.11 **Standard version CSIR NJ Series with current electromagnetic relay**

*(Refer to the electric wiring CSIR BOX represented in Figure 19, page 29)*

Verify with a voltmeter the correct voltage on the terminals 4 and 5 of the starting relay. If there is insufficient voltage, the thermostat is defective due to open contacts, connections, or there is an interruption in the cables.

Disconnect the other electric components if present (motor fan, motor-gear, etc.), interrupt the voltage to the circuit at the supply line, and carry out the following operations and checks:

1. Disconnect all the connections on terminals 2 and 5 of the starting relay.
2. Check the continuity between terminals 2 and 5 of the starting relay. If there is no continuity, there is an interruption on the coil and the relay must be replaced.
3. Check the continuity between the terminals 1 and 2 of the starting relay. If there is continuity, the contact is open and the relay must be replaced.
4. Check the protector the continuity between the points 1 and 3. If there is no continuity, the protector can be defective or tripped, then repeat the check after about 10 minutes.
5. Check the electric motor according to the procedure described in section 7.5.1.
6. Check the ohmic resistance of the stator run and start windings according to the procedure described in section 7.5.2.
7. Check the start capacitor according to the procedure described in section 7.5.3.
8. Check the continuity of the cables disconnected from the terminals 2 and 5 of the start relay.

If from all above checks, no problem was found, there is no clogging in the expansion device and the system does not yet run correctly, replace the starting relay, excluding possible mistakes of opening and closing of the contacts (pick-up and drop-out currents) that cannot be determined with above checks.

If the compressor does not yet run correctly it must be replaced due to an internal defects.

#### 7.4.12 **Three-Phase Version NJ**

*(Refer to the electric wiring THREE-PHASE represented in Figure 20, page 29)*

Verify with a voltmeter the presence of the correct voltage of the three phases, on the three pins of the hermetic terminal. If there is insufficient voltage, check the presence of a break on the contacts of relay, cables and connections.

Disconnect the other electric components if present (motor fan, motor-gear, etc.), interrupt the voltage to the circuit at the supply line, and carry out the following checks:

1. Check the continuity of the windings of the three phase electric motor, among the pins of the hermetic terminal (3 measures carried out between 2 pins at a time). The lack of continuity indicates an interruption in the electric motor winding.
2. Check the continuity among the three pins of the hermetic terminal and the ground plate on the compressor. If there is continuity, the electric motor has the windings shorted.
3. Check with a suitable instrument the ohmic resistance of the three phases of the stator windings, through the three pins of the hermetic terminal on the compressor.



The values of resistance indicated on the Electric Components List must result within the tolerance of  $\pm 10\%$  at the ambient temperature of 25 °C.

**PLEASE NOTE:** Each of the three phases can have different ohmic resistance values.

If from all above checks no problem was found, there is no clogging in the expansion device and the system still does not run correctly, replace the compressor.

## 7.5 CONTROL PROCEDURES

### 7.5.1 Control of electric motor stator windings

- Check the continuity between the pins C and S of the hermetic terminal. If there is no continuity, there is an interruption in the electric motor start winding.
- Check the continuity between the pins C and R of the hermetic terminal. If there is no continuity, there is an interruption in the electric motor run winding.
- Check the continuity between the pin C of the hermetic terminal and the ground plate on the compressor. If there is continuity, the electric motor windings are shorted to ground.

### 7.5.2 Control of stator windings ohmic resistance

- Check with a suitable instrument the ohmic resistance of the start and run stator windings through the three pins of hermetic terminal on compressor.

The values  $R_m$  and  $R_a$  indicated on the Electric Components List must be within the tolerance of  $\pm 10\%$  at ambient temperature of 25 °C, measured on the pins C-R for run and C-S for start.

### 7.5.3 Control of start and run capacitors

- Before checking the electrolytic start capacitor, unsolder one of the two wire terminals of the bleed resistor which is connected between the two terminals.
- Check the start and run capacitor on the two terminals, using an indicating pointer instrument set as in the following:
  - *With ohmmeter scale  $R \times 10$ :* if the pointer moves rapidly from infinity position to zero returning to the infinity position, the capacitor is good.
  - *With ohmmeter scale  $R \times 10$ :* measuring continuity (resistance near to zero) the capacitor is short-circuited and must be replaced.
  - *With ohmmeter scale  $R \times 100000$ :* if no indication is given by the instrument, the capacitor is internally interrupted and it must be replaced.

8

# HOW TO RETURN SUPPLIED PRODUCTS TO EMBRACO EUROPE

8.1

## CONDITIONS

For the warranty on products supplied by Embraco Europe Srl, refer to what is indicated in the sales conditions.

The validity of the warranty is subject to the following conditions and to the results of the Technical Report sent to the Customer by the Sales and Marketing Department. The Customer must advise the Sales and Marketing Department about the defect found on the product and supply all useful data for a preliminary analysis. If necessary, it can be agreed upon with the Customer that the return of defective material can be sent to Embraco Europe Product Quality Assurance Laboratory with detailed information on the defect, which is necessary for a rapid and accurate analysis. The Bill of Lading accompanying the material should report the following description:

1. **“Return of rejected product”**: defective material to be returned for analysis. In this case, depending upon the warranty conditions and the analysis results, the material can be replaced with new components.
2. **“Sending for destructive tests”**: for material to be submitted to destructive tests, without warranty conditions. In this case, all or some of the defective material can be returned to the customer, if required.

**PLEASE NOTE:** Due to administrative reasons, never indicate on the delivery note “in vision account” or “in pending account”.

In case of incorrectly shipped material, the customer, with reference to the Embraco Bill of Lading, must inform the Sales Department, who will see to correct the error.

The Bill of Lading accompanying the material should report the following description:

1. **“Returned material not corresponding to the order”**, for the material shipped not in accordance to the order.
2. **“Returned material in quantity exceeding the order”**, for the material supplied in greater quantity versus the order.

The defective material sent to Embraco Europe by the Customer, must comply to the following conditions:

- **The compressors must:**
  - be provided with nameplate and sealed with original plugs.
  - not be emptied of the oil remaining after the disassembling from the system.
  - be handled and transported in order not to suffer strong shocks, falls and possible damages.
  - be equipped with electrical components, properly marked (compressor and electrical components) to allow their correct coupling.
- All materials must be properly packaged according to the type of shipment and in order not to suffer damages during transport.
- The material returned for analysis must be accompanied by a detailed description of the failure, how it happened and all useful data for a correct diagnosis of the defect.

- **Do not return defective compressors as a consequence of mishandling.**
- **Do not return open compressors or tampered components.** (To avoid erroneous diagnosis, the compressors must be opened with suitable tools, available only at Embraco Europe).

The material that does not correspond to the above requirements may be considered not valid for analysis and may void the warranty.

All the material that, after analysis, may appear to be working and are free of quality problems, can neither be returned nor replaced (the complete analysis involves the opening of the compressor and its disassembling).

The analyzed product, before its dismantling, remains at the customer's disposal for a minimum period of 30 days starting from the date in the Technical Report issued by the Sales and Marketing Department.

For the Aspera compressors returned to Embraco Europe, the Customer will get a credit based on the scrap value of the dismantled material.

**8.2**

**TESTS ON THE CUSTOMER APPLICATIONS**

Embraco Europe Srl puts at the customer's disposal the "Application Tests Laboratory", to perform the tests for verifying the running of their equipment; for defining the compressor and the main components of the refrigeration system (condenser, evaporator, capillary) and other special tests.

The customer can request from the "Technical Liaison - Sales & Marketing Department" to agree on the feasibility of the requested test, the delivery of the equipment and the terms, according to the development program of the laboratory tests.

The equipment must be sent to the "Application Tests Laboratory" with the Bill of Lading reporting the following description:

1. **"For destructive tests"** The equipment will not to be returned to the Customer unless agreed differently.

**PLEASE NOTE: THE TRANSPORT EXPENSES ARE CHARGED TO THE CUSTOMER**

The test results will be given to the customer, who can use them as information or to define or modify his application.

**PLEASE NOTE: THE TEST RESULTS CANNOT BE USED IN CASE OF CONTROVERSY AND ACTIONS BROUGHT AGAINST A THIRD PARTY, UNLESS THERE IS A WRITTEN AUTHORIZATION FROM EMBRACO EUROPE Srl.**







Brazil

Rui Barbosa, 1020 - P.O. BOX 91  
89219-901 - Joinville - SC - Brazil  
Phone: +55 47 3441-2121  
Fax: +55 47 3441-2780



Italy

Via Buttigliera 6  
10020 - Riva Presso Chieri (Torino) - Italy  
P.O. BOX 151 - 10023 Chieri (TO)  
Phone: +39 011 943-7111  
Fax: +39 011 946-8377  
+39 011 946-9950

Sales Office  
Zona Industriale D1- Via Fratelli Gambino, 7  
10023 - Chieri (Torino) - Italy  
Phone: +39 011 940-5611  
Fax: +39 011 940-5656



Slovakia

Odorinska Cesta, 2 - 052-01  
Spišská Nová Ves - Slovakia  
Phone: +42 153 417-2291  
+42 153 417-2293  
Fax: +42 153 417-2299

Sales Office  
Zona Industriale D1 - Via Fratelli Gambino, 7  
10023 - Chieri (Torino) - Italy  
Phone: +39 011 940-5611  
Fax: +39 011 940-5656



U.S.A.

2800 Vista Ridge Drive NE  
Suwanee, GA 30024-3510  
Phone: +1 678 804 1337  
Fax: +1 678 804 1338

México - Sales Office  
Torre Alestra, Piso 3 - Office 373  
Av. Lázaro Cárdenas 2321 Pte.  
P.O. BOX 66260 - San Pedro Garza García  
Nuevo León - México  
Phone: +52 81 1001-7102  
Fax: +52 81 1001-7142



China

29 Yuhua Road  
Area B of Beijing Tianzhu Airport Industrial Zone  
101312 - Beijing - China  
Phone: +86 10 8048-2255  
Fax: +86 10 6725-6825