

# EWPC 901 rel. 3/97 ing

## temperature controller with single output

### WHAT IT IS

The EWPC 901 is a temperature controller specifically designed for refrigeration applications.

### HOW IT IS MADE

- **Dimensions:** front 74x32 mm (2.913x1.260"), depth 67 mm (2.637")
- **Mounting:** flush panel mount with mounting bracket
- **Protection:** the instrument front-panel is waterproof IP65; an optional snap-on cover can be supplied to provide additional protection of the rear terminal block
- **Connections:** screw terminal block (2.5 mm<sup>2</sup>; one wire each terminal only, in compliance with VDE norms)
- **Display:** 12.5 mm LED (0.50")
- **Push buttons:** located on front panel
- **Output:** one (1) SPDT relay 8(3)A 250V AC
- **Input:** PTC probe
- **Resolution:** 1 °C (°F)
- **Accuracy:** better than 0,5% of full scale
- **Power supply (depending on model):** 12 Vac/dc or 24 Vac/dc

### GENERAL DESCRIPTION

The EWPC 901 is a temperature controller specifically designed for refrigeration applications; it is designed to operate as a cooling control, which means that the switching differential is positive: the compressor cuts off at setpoint and is started at a temperature of set plus differential. In addition, the EWPC 901 offers several system protection features, all easy to understand and easy to program.

With a suitable setting of parameter "HC" and a negative differential the controller can be used for heating applications. The relay is OFF at setpoint and is energized at a temperature of set minus differential.

A number of parameters are displayed alphanumerically to set up the instrument for each specific application.

The EWPC 901 is supplied in the popular "32x74" ELIWELL.

### FRONT KEYPAD

**SET:** push to display the setpoint temperature. The setpoint can be changed within 5 seconds with the "UP" or "DOWN" button. The control will automatically switch back to normal operating mode within 5 seconds; the last entered setpoint will stay in memory.

**UP:** used to increase the setpoint value, as well as the parameter when in programming. When held down for a few seconds, the change rate accelerates.

**DOWN:** used to decrease the setpoint value, as well as the parameter when in programming. When held down for a few seconds, the change rate accelerates.

**Led "ON":** status light of the output.

### PARAMETER PROGRAMMING

Programming is easily accessed by holding the "SET" button down for more than 4 seconds. The first parameter is displayed; other parameters are accessed with the

"UP" and "DOWN" button. With the "SET" button, the actual setting of each parameter is displayed. To change a parameter setting, push the "SET" plus the "UP" or "DOWN". The system will automatically return to its normal operating mode a few seconds after the programming procedure is completed or interrupted.

### DESCRIPTION OF PARAMETERS

**HC:** Heating / Cooling mode.

Relay switch function.

H = heating;

C = cooling.

**d:** switching differential (hysteresis).

Set with positive value for cooling applications; a negative value is used for heating mode.

**LS:** Lower Set.

Setting of the lower user-access setpoint limit.

**HS:** Higher Set.

Setting of the upper user-access setpoint limit.

**CA:** Calibration.

Temperature read-out offset to allow for possible error due to probe location.

**rP:** relay Protection.

Select relay status in case of probe defect. on = compressor ON in case of probe defect;

oF = compressor OFF in case of probe defect.

**PS:** Protection System short cycle.

Select type of compressor protection desired (the actual time delay is set with the next parameter; only for cooling applications):

0 = delay before start - in seconds;

1 = delay before start - in minutes;

2 = delay after stop - in minutes;

3 = delay between starts - in minutes.

**Pt:** Protection time.

Time delay setting for compressor short-cycle protection (only for cooling applica-



## DEFAULT SETTINGS - STANDARD MODELS

Parameter	Description	Range	Default	Unit
HC	Heating / Cooling	H / C	C	flag
d	differential	-15...15	2	°C / °F
LS	Lower Set	-55...99	-55	°C / °F
HS	Higher Set	-55...99	99	°C / °F
CA	CAlibration	-15...15	0	°C / °F
rP	relay Protection	on / oF	oF	flag
PS*	Protection System	0...3	0	number
Pt*	Protection time	0...31	0	min / sec

\* only for cooling applications

## CONNECTIONS

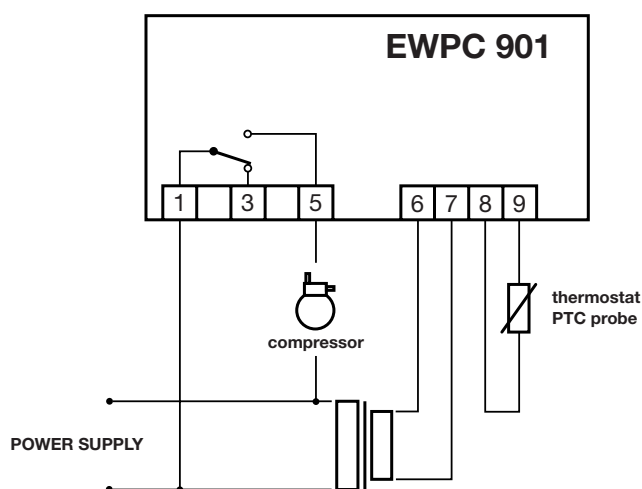

**Protection:** the instrument frontpanel is waterproof IP65; an optional snap-on cover can be supplied to provide additional protection of the rear terminal block.

**Connections:** screw terminal block (2.5 mm<sup>2</sup>; one wire each terminal only, in compliance with VDE norms).

**Display:** 12.5 mm LED (0.50").

**Push buttons:** located on front panel.

**Data storage:** non-volatile EEPROM memory.

**Operating temperature:** -5...65 °C; (23...149 °F).

**Storage temperature:** -30...75 °C; (-22...167 °F).

**Output:** one (1) SPDT relay 8(3)A 250V AC.

**Input:** PTC probe.

**Resolution:** 1 °C (°F).

**Accuracy:** better than 0.5% of full scale.

**Power supply** (dep. on model): 12 Vac/dc ±15% or 24 Vac/dc ±15%.

### Eliwell S.p.A.

via dell'Artigianato, 65  
Zona Industriale  
32010 Pieve d'Alpago (BL)  
Italy

Telephone +39 (0)437 986111

Facsimile +39 (0)437 989066

**A Siebe Group Company**

tions); expressed in seconds (0 to 31) if PS = 0 or in minutes (0 to 31) if PS > 0 (see parameter "PS").

### INSTALLATION

The instrument is designed for flush panel mounting. Insert the unit through a 29x71 mm panel cut-out and affix with the U-bracket supplied.

The ambient temperature around the instrument should be kept between -5 and 65 °C (23...149 °F). Select a location which will not be subject to high humidity or condensation and allow some ventilation to provide cooling to the instrument.

### ELECTRICAL WIRING

The instrument is equipped with an internal screw terminal block suitable for max 2.5 mm<sup>2</sup> wiring (one wire each terminal only, in compliance with VDE norms).

Make sure that the power supply corresponds with the rating shown on the instrument, i.e. 12 Vac/dc ±15% or 24 Vac/dc ±15%.

The 2-wire PTC type probe does not require polarity and can easily be extended by using common 2-lead wire.

It is strongly recommended to run the probe cable separate from line voltage wiring. Also, it is good practice to install the tip of the probe in upright position, to avoid

moist from entering into the stainless steel sensor housing.

The output relay contacts are voltage-free and are suitable for in-line switching of compressors up to 0.5 HP at 220 Vac (or 0.25 HP to 110 Vac). For larger loads, an external contactor must be used.

### ERROR ANNOUNCEMENT

The instrument is provided with only one error message "E1", both in case of shorted sensor and in case of sensor break, or sensor absence. The "E1" error message also appears in the event of underrange of the system temperature (-55).

In the event of overrange of the system temperature (99), the "99" value will blink first, then the "E1" error message will be displayed in case the probe will exceed the value of 150 (values above 99 will not be visualized on the display).

It is recommended to doublecheck the sensor wiring before diagnosing a probe as defective.

### TECHNICAL DATA

**Housing:** black ABS plastic, autoestinguish.

**Dimensions:** front 74x32 mm (2.913x1.260"), depth 67 mm (2.637").

**Mounting:** flush panel mount with mounting bracket.