





# **XC645CX**

**(v. 2.9)**

# INDEX

<b>1.</b>	<b>GENERAL WARNING</b>	<b>4</b>
1.1	 PLEASE READ BEFORE USING THIS MANUAL	4
1.2	 SAFETY PRECAUTIONS	4
<b>2.</b>	<b>GENERAL DESCRIPTION</b>	<b>4</b>
<b>3.</b>	<b>COMPONENTS RELATED TO THE XC645CX</b>	<b>5</b>
3.1	CWC15KIT AND CWC30KIT: WIRING KITS	5
3.2	CABCJ15 OR CABCJ30: 2 PIN CONNECTORS	5
3.3	PP07, PP11, PP30 PP50: 4÷20MA PRESSURE TRANSDUCERS	6
3.4	NP4-67: PIPE MOUNTING TEMPERATURE PROBE	6
3.5	XJ485CX: TTL / RS485 SERIAL CONVERTER	6
<b>4.</b>	<b>WIRING &amp; ELECTRICAL CONNECTIONS</b>	<b>7</b>
4.1	GENERAL WARNINGS	7
4.2	WIRING CONNECTIONS	7
4.3	PROBES CONNECTION	7
4.4	SAFETY DIGITAL INPUTS AND PRESSURE SWITCHES	9
4.5	LOAD CONNECTIONS	9
<b>5.</b>	<b>MOUNTING &amp; INSTALLATION</b>	<b>9</b>
<b>6.</b>	<b>FIRST INSTALLATION</b>	<b>10</b>
6.1	HOW TO SET THE KIND OF GAS	10
6.2	HOW TO SET THE RANGE OF THE PRESSURE PROBES	11
<b>7.</b>	<b>USER INTERFACE</b>	<b>11</b>
7.1	DISPLAYING	12
7.2	KEYBOARD	12
7.3	ICONS	12
<b>8.</b>	<b>HOW TO SEE AND MODIFY THE SET POINT(S)</b>	<b>13</b>
8.1	HOW TO SEE THE SET POINT OF COMPRESSORS AND/OR FANS	13
8.2	HOW TO MODIFY THE SET POINT OF COMPRESSORS AND/OR FANS	13
<b>9.</b>	<b>THE INFO MENU</b>	<b>14</b>
<b>10.</b>	<b>PARAMETERS PROGRAMMING</b>	<b>14</b>
10.1	HOW TO ENTER THE "PR1" PARAMETER LIST	14
10.2	HOW TO ENTER IN PARAMETERS LIST "PR2"	15
10.3	HOW TO CHANGE PARAMETER VALUES	15
<b>11.</b>	<b>HOW TO DISABLED AN OUTPUT</b>	<b>15</b>

11.1	HOW TO DISABLE AN OUTPUT DURING A MAINTENANCE SESSION.	15
11.2	OUTPUT DISABLED SIGNALING.	16
11.3	REGULATION WITH SOME OUTPUTS DISABLED.	16
<b>12.</b>	<b><u>RUNNING HOURS OF LOADS</u></b>	<b>16</b>
12.1	HOW TO DISPLAY THE RUNNING HOURS OF A LOAD.	16
12.2	HOW TO RESET THE RUNNING HOURS OF A LOAD.	16
<b>13.</b>	<b><u>ALARM MENU</u></b>	<b>16</b>
13.1	HOW TO SEE THE ALARMS	16
<b>14.</b>	<b><u>KEYBOARD LOCKING</u></b>	<b>17</b>
14.1	HOW TO LOCK THE KEYBOARD	17
14.2	TO UNLOCK THE KEYBOARD	17
<b>15.</b>	<b><u>USE OF THE PROGRAMMING “HOT KEY “</u></b>	<b>17</b>
15.1	HOW TO PROGRAM A HOT KEY FROM THE INSTRUMENT (UPLOAD)	17
15.2	HOW TO PROGRAM AN INSTRUMENT USING A HOT KEY (DOWNLOAD)	17
<b>16.</b>	<b><u>LIST OF PARAMETERS</u></b>	<b>18</b>
16.1	PLANT DIMENSIONING AND TYPE OF REGULATION.	18
16.2	PROBES CONFIGURATION	19
16.3	OTHERS INPUTS CONFIGURATION	20
16.4	DISPLAY AND MEASUREMENT UNIT	21
16.5	COMPRESSOR REGULATION	21
16.6	LIQUID INJECTION THERMOSTAT	22
16.7	FANS REGULATION	22
16.8	ALARMS – COMPRESSOR SECTION	23
16.9	ALARMS – DLT SECTION	23
16.10	ALARMS – FANS SECTION	23
16.11	DYNAMIC SET POINT FOR FAN	24
16.12	ANALOG OUTPUT (OPTIONAL)	24
16.13	OTHER	25
<b>17.</b>	<b><u>TYPE OF REGULATION</u></b>	<b>25</b>
17.1	DIGITAL SCROLL REGULATION	25
17.2	PROPORTIONAL BAND REGULATION - ONLY FOR FANS	28
17.3	CONDENSER WITH INVERTER – ANALOG OUTPUT SETTING	29
<b>18.</b>	<b><u>ALARM LIST</u></b>	<b>30</b>
18.1	TYPES OF ALARMS AND SIGNALING MANAGED	30
18.2	BUZZER MUTING	32
18.3	ALARM CONDITIONS – SUMMARY TABLE	33
<b>19.</b>	<b><u>TECHNICAL FEATURES</u></b>	<b>35</b>
<b>20.</b>	<b><u>PARAMETERS – DEFAULT VALUES</u></b>	<b>36</b>

# 1. GENERAL WARNING

## 1.1 Please read before using this manual

- This manual is part of the product and should be kept near the instrument for easy and quick reference.
- The instrument shall not be used for purposes different from those described hereunder. It cannot be used as a safety device.
- Check the application limits before proceeding.
- Dixell Srl reserves the right to change the composition of its products, even without notice, ensuring the same and unchanged functionality.

## 1.2 Safety Precautions

- Check the supply voltage is correct before connecting the instrument.
- Do not expose to water or moisture: use the controller only within the operating limits avoiding sudden temperature changes with high atmospheric humidity to prevent formation of condensation
- Warning: disconnect all electrical connections before any kind of maintenance.
- The instrument must not be opened.
- In case of failure or faulty operation send the instrument back to the distributor or to "Dixell S.r.l." (See address) with a detailed description of the fault.
- Consider the maximum current which can be applied to each relay (see Technical Data).
- Ensure that the wires for probes, loads and the power supply are separated and far enough from each other, without crossing or intertwining.
- Fit the probe where it is not accessible by the end user.
- In case of applications in industrial environments, the use of mains filters (our mod. FT1) in parallel with inductive loads could be useful.

# 2. General description

The XC645CX is designed to manage both compressors and fans in a condensing system such as a pack.

The compressors can be digital scroll, simple, multistage.

Control is by means of a neutral zone or proportional band and is based on the pressure or temperature sensed in the LP suction (compressors) and HP (condenser) circuits. A special algorithm balances the run hours of the compressors to distribute the work load uniformly.

The controllers can convert both LP and HP pressures and displays them as temperatures.

The front panel offers complete information on the system's status by displaying the suction and condenser pressure (temperatures), the status of the loads, possible alarms or maintenance conditions.

Each load has its own alarm input that is able to stop it when activated. To guarantee the total system's safety, there are also two inputs for low and high pressure switches: when these are activated, the system is stopped.

By means of the HOT KEY the controller can be easy programmed at power on.

The controller can be connected to the X-WEB, controlling and monitoring system, thanks to the serial TTL output, using the standard ModBus RTU protocol.

### 3. COMPONENTS RELATED TO THE XC645CX

Name	Description	Part number
Transformer	TF5 230V/12Vac	CD050010 00
Wiring kit 1.5m and 3m	CWC15-Kit (1,5m) CWC30-Kit (3,0m)	DD500101 50 DD500103 00
Female disconnect able connector for digital input or analog output (4pcs)	CABCJ15 (1,5m) CABCJ30 (3,0m)	DD200101 50 DD200103 00
TTL /RS485 serial converter	XJ485CX+CABRS02	J7MAZZZ9AA
4-20mA suction pressure transducer	PP11 (-0.5÷11bar)	BE009302 07
4-20mA condenser pressure transducer	PP30 (0÷30bar)	BE009302 04
Hot key for programming	HOT KEY 4K	DK00000100

#### 3.1 CWC15KIT and CWC30KIT: wiring kits

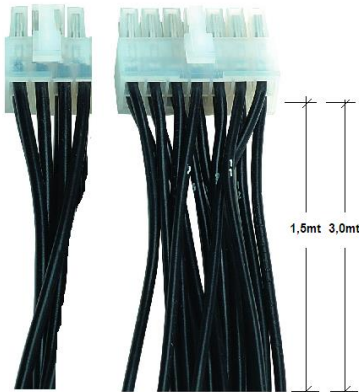

The XC645CX is provided with 2 socket connectors with 14 and 6 pins.

For the wiring the **CWC15KIT** (1.5m cable length) or **CWC30KIT** (3.0m cable length) have to be used.

#### 3.2 CABCJ15 or CABCJ30: 2 PIN connectors



**NOTE:**

Use the connection cable **CABCJ15** (1.5m length) or the **CABCJ30** (3.0m length) for the:

- **HP digital input** (25-26),
- **i2F configurable digital input** (27-28),
- **0-10Vdc or 4-20mA analogue output** (23-24)
- **oA6**, 12Vdc/40mA digital output (21-22) :

### 3.3 PP07, PP11, PP30 PP50: 4÷20mA pressure transducers

PP07 - PP11 - PP30 - PP50 Bar

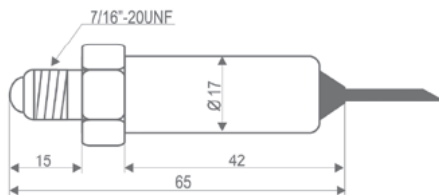

**PP07** 2,0MT -0,5+7bar rel FE  
cod BE009302 00

**PP11** 2,0MT -0,5+7bar rel FE  
cod BE009302 07

**PP30** 2,0MT 0+307bar rel FE  
cod BE009302 04

**PP50** 2,0MT 0+507bar rel Male  
cod BE009002 07

PP30FE

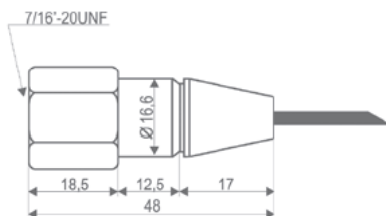

### 3.4 NP4-67: pipe mounting temperature probe

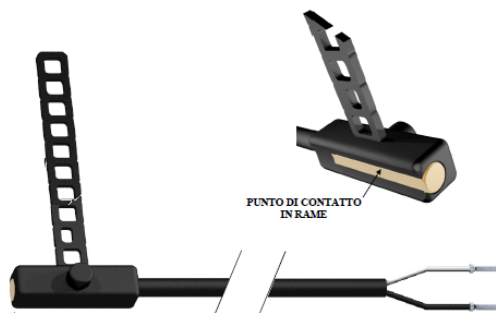

The **NP4-67** temperature probe can be used on the discharge line to monitor the discharge temperature of the Digital Scroll compressor.

**NP4-67** 1.5MT NTC probe  
Measurement range: -40+110°C,  
Cable 1,5mt  
Code BN609001 52

### 3.5 XJ485CX: TTL / RS485 serial converter

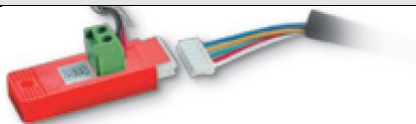

The **XJ485CX** is a TTL/RS485 external converter. Insert it into the TTL receptacle to convert the TTL output into a RS485 (+) and (-) signal for the monitoring system MODBUS\_RTU compatible. (XWEB).

## 4. WIRING & ELECTRICAL CONNECTIONS

### 4.1 General warnings

Before connecting cables make sure the power supply complies with the instrument's requirements.

Separate the probe cables from the power supply cables, from the outputs and the power connections.

**Do not exceed the maximum current allowed on each relay 5A resistive**, in case of heavier loads use a suitable external relay.

### 4.2 Wiring connections

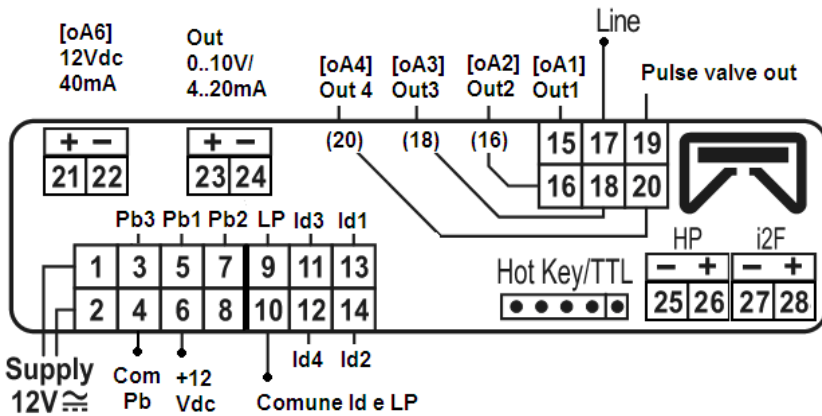

**24Vac/dc supply:** use terminals 1-2

- Always use a class 2 transformer with minimum power 5VA such as TF5.

- Terminals [21-22], [23-24], [25,26], [27-28] are provided with JST 2 PINS connectors, they require the CAB CJ15 (1,5mt) or CAB CJ30 (3mt) wiring cables

### 4.3 Probes connection

#### 4.3.1 General warnings

If using terminal ends be sure there are no bare parts which could cause short circuiting or introduce noise disturbance at high frequencies. To minimize the induced disturbances use shielded cables with the shield connected to earth.

**Pressure probe (4 - 20 mA):** respect the polarity. If using terminal ends be sure there are no bear parts which could cause short circuiting or introduce noise disturbance at high frequencies. To minimize the induced disturbances use shielded cables with the shield connected to earth.  
**Temperature probe:** it is recommended to place the temperature probe away from direct air streams to correctly measure the temperature.

### 4.3.2 Probe wirings

**Low voltage side (14PINs connector):** Keep the cables away from the power cables. Use shielded cable to lengthen the cables.

**NOTE1: The PIN 4** is the common line for the temperature probes

**NOTE2: The PIN 6** gives a 12Vdc supply for the 4-20mA pressure transducers

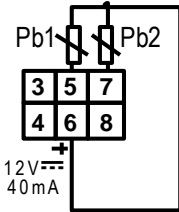
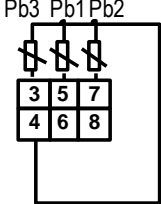
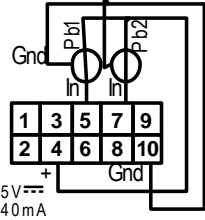
<p><b>PP07 PP11, PP30, PP50 4÷20mA pressure transducers</b> respect the polarity.  <b>Suction (P1C = Cur)</b>            Brown (+) to terminal 6 ; white (-) to terminal 5  <b>Condenser (P2C = Cur)</b>            Brown (+) to terminal 6 ; white (-) to terminal 7</p>	
<p><b>Temperature probes (NTC 10K)</b>  <b>Suction: 4-5 (P1C = NTC)</b>  <b>Condenser: 4-7 (P2C =NTC)</b>  <b>Pb3 (P3C = NTC): 4-3</b></p>	
<p><b>Ratiometric transducers (0.5÷4.5Vdc)</b>  <b>Suction (P1C = 0-5)</b>            5 (In); 4(+); 10 (gnd)  <b>Condenser (P2C =0-5)</b>            7 (In); 4(+); 10 (gnd)</p>	



## 4.4 SAFETY DIGITAL INPUTS AND PRESSURE SWITCHES

**!!!WARNING: free voltage inputs!!!!**

**NOTE: The PIN 10 is the common line for all the digital inputs.**

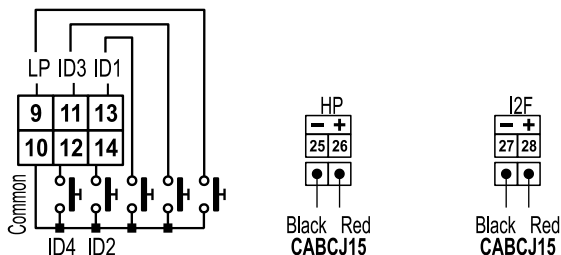

## 4.5 LOAD CONNECTIONS

**!!!WARNING: Digital Scroll valve coil MUST operate at main voltage (230Vac or 115Vac)!!!!**

**NOTE: Main voltage side (6PINs connector): the PIN 17 is the common line for all the relay outputs and for the TRIAC.**

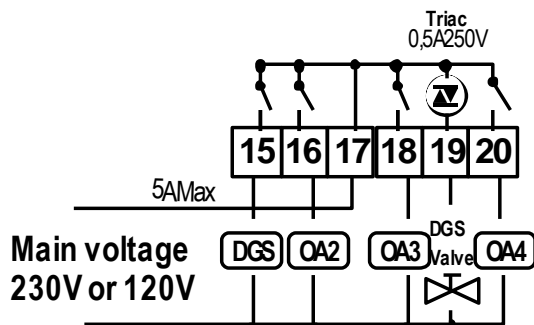

## 5. Mounting & installation

The instruments are suitable only for internal use. Instruments shall be mounted on panel, in a 29x71 mm hole, and fixed using the special brackets supplied.

The ambient operating temperature range is between  $-10\div 60^{\circ}\text{C}$ .

Avoid locations subject to heavy vibration, corrosive gases or excessive dirt. The same applies to the probes. Ensure ventilation around the instrument.

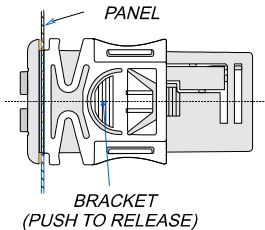
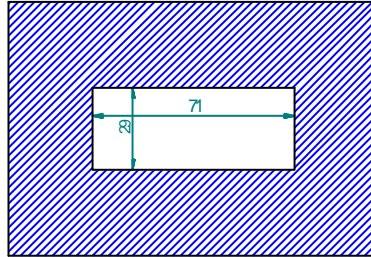
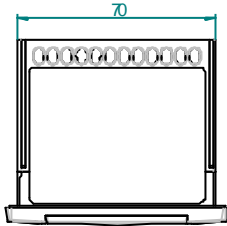
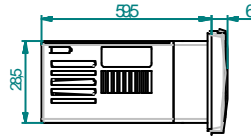
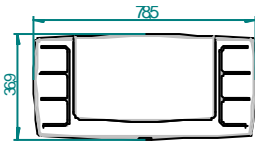

## 6. First installation

At first installation, it's necessary the following:

1. **Select the kind of gas.**
2. **Set the range of the pressure probes.**

In the following paragraph a short cut for the above operations.

Chapters 10 Parameters programming and 16 will show in detail these operations.

### 6.1 How to set the kind of gas

The controller has memorized the relation between temperature and pressure for some gases.

**The pre-set gas is: r407F.**

If another gas is used, act as in the following:

1. Enter the Programming mode by pressing the **Set** and **DOWN** key for 3s.
2. Select the "**Pr2**" parameter. Then enter the password **3 2 1 0**.
3. Select the **FtyP, kind of gas**, parameter.
4. Press the "**SET**" key: the value of the parameter will start blinking.
5. Use "**UP**" or "**DOWN**" to change the gas among the following: **r22** = R22; **404A**= R404A; **407A**= R407A; **407C**= R407C; **407F**= R407F; **410A** = r410; **r507**= R507; **r134**=134; **co2** = CO2 (carbon dioxide)

6. Press “**SET**” to store the new value and move to the following parameter.

**To exit:** Press **SET + UP** or wait 30s without pressing a key.

**NOTE:** the set value is stored even when the procedure is exited by waiting the time-out to expire.

## 6.2 How to set the range of the pressure probes

If an instrument with the following part number is used: XC645CX – xxxxF, it is pre-set to work with pressure probe with the following range:

Probe 1:  $-0.5 \div 11.0$  bar (relative pressure);

Probe 2:  $0 \div 30.0$  bar (relative pressure)

If the probes you’re using have a different range act as in the following:

To set the pressure range of the **Probe 1 (suction probe)** use the parameter:

**PA04: Adjustment of read out corresponding to 4mA (0.5V)**

**PA20: Adjustment of read out corresponding to 20mA (4.5V)**

Practically these parameters have to be set with the start and end scale of the probe range.

### How to do:

1. Enter the Programming mode by pressing the **Set** and **DOWN** key for 3s.
2. Select the “**Pr2**” parameter. Then enter the password 3 2 1 0.
3. Select the **PA04, adjustment of read out corresponding to 4mA (0.5V)**, parameter.
4. Press the “**SET**” key: the value of the parameter will start blinking.
5. Set the lower value of the probe range.
6. Push the **SET** key to confirm the value. The **PA20: adjustment of read out corresponding to 20mA (4.5V)** parameter will be displayed.
7. Set the higher value of the range.
8. Push the **SET** key to confirm the value. Next parameter will be displayed.

Do the same things for the Probe 2, **FA04**, **FA20** parameters.

## 7. User interface



## 7.1 Displaying

UPPER DISPLAY	LOWER DISPLAY	ICONS
Suction temperature or pressure	Discharge temperature or pressure	- Working loads - Measurement unit - Alarm or status Icons

## 7.2 Keyboard

### SET (SET)

**Standard visualization:** to see or modify the set point. In programming mode it selects a parameter or confirms an operation.

**Alarm menu:** By holding it pressed for **3s**, the current alarm is erased.

### ▲ (UP).

**In programming mode:** it browses the parameter codes or increases the displayed value.

**With Hot key inserted:** it starts the Hot key programming procedure.

**To access the INFO menu:** push and release it to access the INFO menu.

### ▼ (DOWN)

**In programming mode:** it browses the parameter codes or decreases the displayed value.



**Manual restart of loads:** By holding it pressed for **3s**, it switches on again loads previous locked by a safety digital input alarm.



**MAINTENANCE/CLOCK:** To display the loads running hours  
By holding it pressed for 3s the **Maintaining menu** is entered



**To enter the Alarm menu**

### KEY COMBINATIONS













▲ + ▼ To lock and unlock the keyboard.

SET + ▼ To enter the programming mode.

SET + ▲ To exit the programming mode.

## 7.3 Icons

LED	FUNCTION	MEANING
°C	ON	Celsius degrees
°F	ON	Fahrenheit degrees
bar	ON	bar displaying
PSI	ON	PSI displaying
kPa	ON	KPA displaying
1	ON	Digital scroll compressor (DGS) on
1	Flashing	DGS is waiting to start (1HZ) or digital input alarm for DGS (2Hz). or DGS in maintenance status (2Hz).
2	ON	Load 2 on

	Flashing	Load 2 is waiting to start (1HZ). or digital input alarm for Load 2 (2Hz). o Load 2 in maintenance status (2Hz).
	ON	Load 3 on
	Flashing	Load 3 is waiting to start (1HZ). or digital input alarm for Load 3 (2Hz). o Load 3 in maintenance status (2Hz).
	ON	Load 4 on
	Flashing	Load 4 is waiting to start (1HZ). or digital input alarm for Load 4 (2Hz). o Load 4 in maintenance status (2Hz).
	ON	Load 6 on
	Flashing	Load 6 is waiting to start (1HZ). or digital input alarm for Load 6 (2Hz). o Load 6 in maintenance status (2Hz).
	ON	The valve of the Digital scroll compressor is energized
	ON	The Maintenance menu has been entered
	Flashing	One or more loads have been placed in maintenance status
<b>LP</b>	ON	Low pressure switch alarm
<b>HP</b>	ON	High pressure switch alarm
	ON	Alarm is happening
	ON	All the stored alarms have been seen.
	Flashing	A new alarm has happened

## 8. How to see and modify the set point(s)

### 8.1 How to see the set point of compressors and/or fans

If the controller is managing both compressors and fans, both the set points are displayed in sequence, otherwise only the set point of the enabled section will be displayed.

- 1) Push and release the **SET** key;
- 2) The Lower display will show the “**SEtC**” label, will the Upper display will show its value.
- 3) To see the fan set point, push again the **SET** key.
- 4) The Lower display will show the “**SEtF**” label, will the Upper display will show the fan set point.

**To exit:** push the **SET** key or wait for 30 without pressing any keys.

### 8.2 How to modify the set point of compressors and/or fans

**\*\*\*\*\*WARNING: before setting the target set points for the first time, check and, if necessary, modify the type of freon (par. FtyP) and the default unit of measurement (par. dEU) for compressors and fans \*\*\*\*\***

#### PRE-ACTION

1. **Set the kind of freon by means of the FtyP parameter (see 6.1 How to set the kind of gas)**
2. **Set the measurement unit (dEU par.).**
3. **Check and if necessary modify the set point limits (LSE and HSE par.).**

#### PROCEDURE

1. Push the **SET** key for more than 2 seconds;
2. The Lower display will show the “**SEtC**” label, will the Upper display will show its value flashing.
3. To change the Set value, push the ▲ or ▼ within 30s.

4. To memorize the new value and pass to the fan set point, push the **SET** key.
5. The Lower display will show the “**SEtF**” label, will the Upper display will show the fan set point flashing.
6. To change its value, push the ▲ or ▼ within 30s.

**To exit:** push the **SET** key or wait for 30 without pressing any keys.

## 9. The INFO menu

The controller can display some information directly from the main menu.  
The INFO menu is accessible by pushing and releasing the **UP** key:

Here below the list of the information that can be displayed:

**NOTE: this information is displayed only if the related function is enabled**

- **P3:** value of the P3 probe. It's displayed only if the P3 probe is set present (parameter P3c = 10 or 86)
- **LinJ:** status of the injection output (“On” – “OFF”) This information is available only if one relay, oA2 +oA6 is set as “Lin”.
- **SEtd:** value of the **Dynamic Set point**. This information is available only if the Dynamic set point function is enabled (par. dSEP ≠ nP)
- **dStO:** percentage of the PWM output driving the valve of the Digital Scroll compressor.
- **dSFr:** value of temperature or pressure when the regulation filter of Digital Scroll compressor is enabled (par. dFE=YES).
- The “regulation filter” function calculates the average value of the pressure/temperature during a PWM cycle, and uses this value for the control algorithm
- **AOO:** Percentage of the analog output (4-20mA or 0-10V). This information is always available.

**EXIT:** push the **SET+UP** keys together.

## 10. Parameters programming

### 10.1 How to enter the “Pr1” parameter list

To enter the “Pr1” parameter list, user accessible, operate as follows:

1. Hold pressed the **SET** and **DOWN** key for 3s.
2. The controller displays the name of the parameter in the Lower display, its value on the Upper display.
3. Press the “**SET**” key: the value of the parameter will start blinking.
4. Use “**UP**” or “**DOWN**” to change the value.
5. Press “**SET**” to store the new value and move to the following parameter.

**To exit:** Press **SET + UP** or wait 30s without pressing a key.

**NOTE:** the set value is stored even when the procedure is exited by waiting the time-out to expire.

## 10.2 How to enter in parameters list “Pr2”

The “Pr2” parameter list is protected by a security code (Password).

SECURITY CODE is            3210

To access parameters in “Pr2”:

1. Enter the “Pr1” level.
2. Select “Pr2” parameter and press the “SET” key.
3. The flashing value “0 ---” is displayed.
4. Use ▲ or ▼ to input the security code and confirm the figure by pressing “SET” key.
5. Repeat operations 2 and 3 for the other digits.

**NOTE:** each parameter in “Pr2” can be removed or put into “Pr1” (user level) by pressing “SET” + ▼. When a parameter is present also in “Pr1” decimal point of the lower display is on.

## 10.3 How to change parameter values

1. Enter the Programming mode.
2. Select the required parameter with ▲ or ▼.
3. Press the “SET” key the value start blinking.
4. Use ▲ or ▼ to change its value.
5. Press “SET” to store the new value and move to the following parameter.

**To exit:** Press **SET + UP** or wait 15s without pressing a key.

**NOTE:** the new programming is stored even when the procedure is exited by waiting the time-out.

## 11. How to disabled an output

To disabled an output during a maintenance session means to exclude the output from the regulation.

### 11.1 How to disabled an output during a maintenance session.

1. Push the **MAINTENANCE/CLOCK** () key for 3s.
2. The LED's of the first output is switched on, the Lower display shows the “**StA**” label, while the Upper display shows the “**On**” label if the first output is enabled, or the “**oFF**” label if the output is disabled for a maintenance section.  
With compressor with more steps all the LED's linked to the compressor and the valves are switched on..
3. Select the output by pressing the **UP** or **DOWN** key.
4. **To modify the status of the output:** push the **SET** key, the status of the output starts flashing, then push the UP or DOWN to pass from “**On**” to “**oFF**” and vice versa.
5. Push the **SET** key to confirm the status and pass to the next output..

**To exit:** push the **CLOCK** key or wait 30 sec

## 11.2 Output disabled signaling.

If an output is disabled its led blinks (2 Hz)

## 11.3 Regulation with some outputs disabled.

If some outputs are disabled they don't take part to the regulation, so the regulation goes on with the other outputs.

# 12. Running hours of loads

## 12.1 How to display the running hours of a load.

The controller memorizes the running hours of each load.

To see how long a load has been working follow this procedure:

1. Press and release the “**MAINTENANCE/CLOCK** ()” key.
2. The led of the first output is switched on, the **Upper Display** shows the “**HUR**” label, while the **Lower Display** shows the running hours of the first output.
3. To see the running hours of the following load press the UP key .

**To exit:** push the  key or wait 30 sec

## 12.2 How to reset the running hours of a load.

1. Display the running hour according to the above procedure.
2. Select the load by pressing the UP key.
3. Push the **SET** key (immediately on the lower display the **rSt** label is displayed).
4. Hold pushed the key for some seconds till the “**rSt**” label starts flashing and the lower display shows zero.

**To exit:** push the **CLOCK** key or wait 30 sec

**NOTE:** if the **SET** key is released within 2s, the controller reverts to display the running hours of the selected loads..

# 13. Alarm Menu

The controller memorizes the last 20 alarms happened, together with their duration..

To see the alarm codes see par. **par. 18**.

## 13.1 How to see the alarms

1. Push the  **Alarm** key.
2. The last alarm happened is showed on the Upper display, while the lower display shows its number.
3. Push again the **▲** key and the other alarm are displayed starting from the most recent.
4. To see the alarm **duration** and push the **SET** key.
5. By pushing again the **▲** or **SET** key the next alarm is displayed.



### Alarms erasing.

1. Enter the Alarm Menu.
2. To erase the displayed alarm push the **"SET"** key till the "rSt" label will be displayed in the Lower Display,  
**NOTE** the running alarms cannot be erased..
3. To erase the whole Alarm Menu, hold pressed the **"SET"** key for 10s.

## 14. Keyboard locking

### 14.1 How to lock the keyboard

1. Keep the **▲** and **▼** keys pressed together for more than 3 s the **▲** and **▼** keys.
2. The "POF" message will be displayed and the keyboard is locked. At this point it is only possible to view the set point or enter the HACCP menu.

### 14.2 To unlock the keyboard

Keep the **▲** and **▼** keys pressed together for more than 3s till the **"POn"** flashing message appears.

## 15. Use of the programming "HOT KEY "

### 15.1 How to program a hot key from the instrument (UPLOAD)

1. Program one controller with the front keypad.
2. When the controller is **ON**, insert the **"Hot key"** and push **▲** key; the **"uPL"** message appears followed a by flashing **"End"**
3. Push **"SET"** key and the **End** will stop flashing.
4. Turn OFF the instrument remove the **"Hot Key"**, then turn it ON again.

**NOTE:** the **"Err"** message is displayed for failed programming. In this case push again **▲** key if you want to restart the upload again or remove the **"Hot key"** to abort the operation.

### 15.2 How to program an instrument using a hot key (DOWNLOAD)

1. Turn OFF the instrument.
2. Insert a **programmed "Hot Key" into the 5 PIN receptacle** and then turn the Controller ON.
3. Automatically the parameter list of the **"Hot Key"** is downloaded into the Controller memory, the **"doL"** message is blinking followed a by flashing **"End"**.
4. After 10 seconds the instrument will restart working with the new parameters.
5. Remove the **"Hot Key"**..

**NOTE** the message **"Err"** is displayed for failed programming. In this case turn the unit off and then on if you want to restart the download again or remove the **"Hot key"** to abort the operation. The unit can **UPLOAD** or **DOWNLOAD** the parameter list from its own E2 internal memory to the **"Hot Key"** and vice-versa.

## 16. List of parameters

### 16.1 Plant dimensioning and type of regulation.

The XC645CX is pre-set to drive a Digital Scroll compressor.

The relay 15-17 is set to manage the Digital Scroll compressor, while the TRIAC output 17-19 drives its solenoid valve.

**oA2 (term. 16-17), oA3 (term. 17-18), oA4 (term. 17-20), oA6 (term. 21-22) outputs 2 3 4 6 configuration:** by means of these parameters the plant can be dimensioned according to the number and type of compressors and/or fans and the number of steps for each one.

Each relay according to the configuration of the oA(i) parameter can work as:

- **Compressor:** oAi = cPr,
- **Step:** oAi = StP
- **Fan:** oAi = FAn
- **Alarm:** oAi = ALr
- **Injection of cooling liquid:** oAi = Lin
- **Inverter for condensing fan:** oAi = InF
- **Not used:** oAi = nu

**NOTE:** also the "dGs" and "dGS" values are present. These values **must not** be used..

According to the oA2, oA3, oA4, oA6 configuration, 2 kinds of plant can be defined:

**Rack with compressors only:** all the oAi different from FAn

**Rack with compressors and fans:** both FAn and CPr are used for oAi.

**NOTE: COMPRESSOR WITH STEPS CONFIGURATION:** the output of compressor has to be set before the output of the step.

**ES.** Compressor with 1 step: **oA2 = cPr, oA3= StP.**

**If an oAi set as step without any previous oAi set as cPr the configuration alarm "CStP" will be activated.**

#### PLANT CONFIGURATION EXAMPLES:

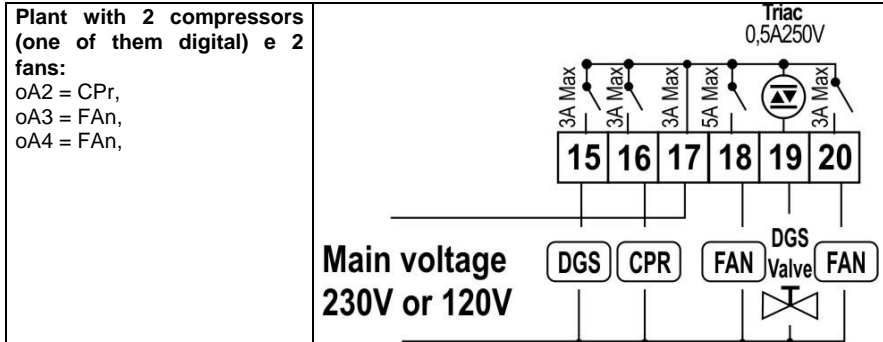

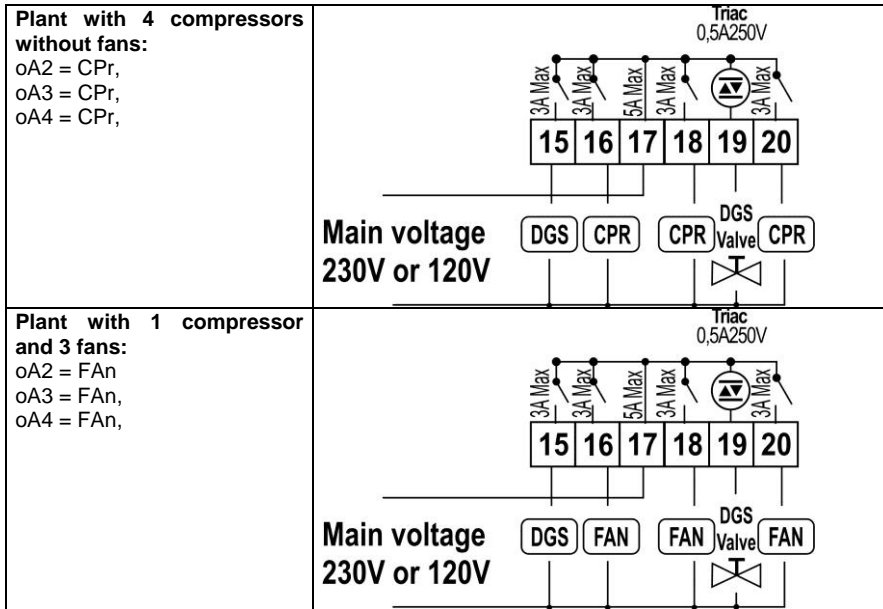

**FtyP:** **Freon Type:** set the kind of freon used in the plant **r22** = R22; **404A**= R404A; **407A**= R407A; **407C**= R407C; **407F**= R407F;**410A** = r410; **r507**= R507; **r134**=134; **co2** = CO2 (carbon dioxide)

**rTy:** **Type of regulation (see par. 17):**  
**db** = neutral zone,- **set this kind of regulation for rack with digital scroll.**  
**Pb** = proportional band.

**rot** **Activation: type of sequence**  
**YES** = rotation: this algorithm distributes the working time between the various loads to ensure even run times.  
**no** = fixed sequence: the compressors are enabled and disabled in fixed sequence: first, second etc.  
**NOTE:** The **digital scroll compressor** is always started as first and switched off as last. In any case, if it is locked because of safety timers, another compressor is started to maintain the pressure in the regulation band.

## 16.2 Probes configuration

Probes can be used in different ways according to plant features, as described in the following table:

### 16.2.1 Suction probe configuration

**P1c:** **Suction probe setting (probe 1):**

**nP** = not used: don't set it;

**Cur** = 4 ÷ 20 mA pressure transducer; use term. 6(+), 5 (in); 10 (gnd) if present

**tEn** = 0.5÷4.5V ratiometric pressure transducer; use term. 4(+), 5 (in); 10 (gnd)

**ntc** = NTC 10K probe; use term. 4- 5

**PA04:** **Adjustment of read out for the Probe 1** (used only if Pbc=Cur or tEn). Corresponding to **4mA** or **0.5V** input signal, given by the suction probe (-1.0 ÷ PA20bar; -15÷PA20PSI; -100 ÷ PA20KPA)

E.I. **PP11** relative pressure transducer, range -0.5÷11.0 bar. PA04=-0.5; PA20=11.0  
**PP30** relative pressure transducer, range: 0÷30bar. PA04=0.0; PA20=30.0.

**PA20: Adjustment of read out for the Probe 1** corresponding to **20mA** or **4.5V** input signal, given by the suction probe (PA04 ÷ 51.0BAR; PA04 ÷ 750PSI; PA04 ÷ 5100KPA).

**CAL: Probe 1 calibration:** the range depends on the dEU parameter:

dEU=bar or °C: -12.0÷12.0;

dEU=PSI or °F: -20÷20;

dEU=kPA: -120÷120;

### **16.2.2 Condenser probe configuration**

**FPb Probe selection for condenser**

**P1** = Not use it

**P2** = Probe 2

**P2c: Condenser probe setting (probe 2):**

**nP** = not used:

**Cur** = 4 ÷ 20 mA pressure transducer; use term. 6(+), 7 (in); 10 (gnd)

**tEn** = 0.5÷4.5V ratiometric pressure transducer; use term. 4(+), 7 (in); 10 (gnd)

**ntc** = NTC 10K probe; use term. 4- 7

**FA04: Adjustment of read out for the Probe 2** (used only if Pbc2=Cur or tEn). corresponding to **4mA** or **0.5V** input signal, given by the delivery probe (-1.0 ÷ FA20bar; -15÷FA20PSI; -100 ÷ FA20KPA)

**FA20: Adjustment of read out for the Probe 2** corresponding to **20mA** or **4.5V** input signal, given by the condensing probe (FA04 ÷ 51.0BAR; FA04 ÷ 750PSI; FA04 ÷ 5100KPA)

**FCAL: Probe 2 calibration** the range depends on the dEU parameter:

dEU=bar or °C: -12.0÷12.0;

dEU=PSI or °F: -20÷20;

dEU=kPA: -120÷120;

### **16.2.3 Probe 3 configuration**

**P3c: Probe 3 setting:**

**nP** = not used:

**10** = NTC 10K

**86** = NTC 86K

**O3: Probe 3 calibration** the range depends on the dEU parameter:

dEU=bar or °C: -12.0÷12.0;

dEU=PSI or °F: -20÷20;

## **16.3 Others inputs configuration**

**i2F Configurable digital input function** (terminals 27-28):

**id5** = not set it

**id6** = Safety digital input for Load 6

**LP** = not set it

**HP** = not set it

**ES** = Energy saving;

**oFF** = instrument shut down;

**LL** = liquid level alarm

**i1P Not used**

**i2P Polarity of the i2F input:** (terminals 27-28)

**oP:** the digital input is activated by opening the contact;

**CL:** the digital input is activated by closing the contact.

**i3P: Polarity of Low pressure-switch alarm** (terminals 9-10)

**oP** =alarm with open contacts; **cL**= alarm with closed contact

**i4P: Polarity of High pressure-switch alarm** (terminals 25-26)

- oP** = alarm with open contacts; **cL**= alarm with closed contact
- did** **i2F digital input delay:** (enabled only if i2F=LL) 0÷255min
- ALIP:** **id1, id2, id3, id4 safety inputs for compressors and fans polarity:**  
**oP:** the digital input is activated by opening the contact;  
**CL:** the digital input is activated by closing the contact.
- ALMr** **Manual reset of alarms for compressors and fans.**  
**no** = automatic recover of alarm: regulation restart when the correspondent digital input is disabled; **yES** = manual recover for the alarms of compressors and fans See also par.18.1.2

## 16.4 Display and Measurement unit

The measurement unit of the parameters referred to temperature or pressure depends on the parameters dEU, CF and PMU.

**NOTE:** The controller automatically converts values of set points and parameters referred to the pressure/temperature when the dEU parameter is changed. In any case check the value of the parameters referred to temperature and pressure after changing dEU.

- dEU:** **Selection of the kind of measurement unit: pressure or temperature**  
**dEU = tMP:** the parameters referred to pressure/temperature will be expressed in temperature according to the value of the CF parameter (°C or °F)  
**dEU = PrS:** the parameters referred to pressure/temperature will be expressed in pressure according to the value of the PMU parameter (bar, PSI or KPA)
- CF** **Measurement unit for temperature:** it is used only with dEU = tMP, and it set the measurement unit for parameters referred to temperature/pressure.  
 °C = Celsius degree  
 °F = Fahrenheit degree
- PMU** **Measurement unit for pressure:** it is used only with dEU = PrS, and it set the measurement unit for parameters referred to temperature/pressure.  
**bar** = bar  
**PSI** = PSI  
**PA** = kPA
- rES** **Resolution for °C and bar (in = integer; dE= decimal point)**
- dFE** **Pressure filter enabling: YES** = enabled; **no** = not enabled; This filter takes in account the average value of the pressure during the last cycle for the regulation.
- dEU1** **Default visualization for upper display: PrS**= Pressure; **tPr**= temperature
- dSP2** **Variable to show on the lower display: nu** = not used; **P1** = probe 1; **P2**= probe 2; **P3**=probe 3; - **SEt1**=Suction set point; **Set2**=Condenser set point)
- dEU2** **Default visualization for lower display: PrS**= Pressure; **tPr**= temperature

## 16.5 Compressor regulation

- Pbd:** **Proportional band or neutral zone width** (0.1÷5.0bar/0.5÷30°C or 1÷150PSI/1÷50°F)  
 The band (or zone) is symmetrical compared to the target set point, with extremes: set-Pbd/2 ÷ set+Pbd/2. It is used as proportional band for PI algorithm.  
 The measurement unit depends on the dEU, CF, PMU par.
- rS** **Proportional band offset:** PI band offset. It permits to move the proportional band of the PI. With **rS=0** the band is between Set-Pbd/2 ÷ Set+Pbd/2;
- inC** **Integration time:** (0 ÷ 999s) PI integration time
- SUt** **Start up time:** The digital scroll valve is energized for the SUt when the compressor starts (0÷3s)
- tdS** **Digital scroll cycle time:** (10÷40s) it sets the cycle time for the digital scroll (DGS) valve modulation.
- PM** **DGS minimum power** (10÷PMA): it sets the minimum capacity allowed to the DGS.

- PMA** **DGS maximum power** (PM÷100) it sets the maximum capacity allowed to the DGS
- ton** **DGS at maximum PMA capacity before starting a new load** (0÷255s)
- toF** **DGS at minimum PM capacity before stopping a load** (0÷255s)
- HPP** **Digital compressor capacity in case of “dLt” or “HA2” alarms:** (0÷PMA%)
- MinP** **Minimum allowed DGS capacity for poor lubrication monitoring** (0÷100%; with 0 function excluded) If the DGS compressor works for the tMin time with a capacity (in percentage) equal or lower than MinP, it is forced to work at 100% for the tMAS time in order to restore the right lubrication.
- tMin** **Maximum DGS functioning time at a capacity lower than MinP, before working at full capacity (PMA)** (1÷255min)
- tMAS** **Time of DGS functioning at maximum capacity (PMA) to restore the right lubrication** (1÷255min)
- ESC** **Energy saving value for compressors:** (-20÷20bar; -50÷50°C) this value is add to the compressor set point.
- onon:** **Minimum time between 2 following switching ON of the same compressor** (0÷255 min).
- oFon:** **Minimum time between the switching off of a compressor and the following switching on.** (0÷255min). *Note: usually onon is greater than oFon.*
- don:** **Time delay between the insertion of two different compressors** (0÷99.5min; res. 10s).
- doF:** **Time delay between switching off of two different compressors** (0÷99.5 min; res. 10s)
- donF:** **Minimum time a stage stays switched ON** (0÷99.5 min; res. 10s)
- Maon** **Maximum time for compressor ON** (0 ÷ 24 h; with 0 this function is disabled.) If a compressor keeps staying on for the MAon time, it's switched off and it can restart after the oFon standard time.
- FdLy:** **“don” delay enabled also for the first call.** If enabled, the triggering of the step is delayed for a “don” value, respect to the call. (**no** = “don” not enabled; **yES**=“don” enabled)
- FdLF** **“doF” delay enabled also for the first switching off.** It enables the “doF” delay between the request of a release and the actual switching off. (**no** = “doF” not enabled; **yES**=“doF” enabled)
- odo:** **Regulation delay on start-up:** (0÷255s) on switching ON the instrument starts working after the time delay imposed in this parameter.
- LSE:** **Minimum set point:** The measurement unit depends on dEU parameter. It sets the minimum value that can be used for the set point, to prevent the end user from setting incorrect values.
- HSE:** **Maximum set point:** The measurement unit depends on dEU parameter. It sets the maximum acceptable value for set point.

## 16.6 Liquid injection thermostat

- Lit:** **Set point ( °C) for cooling injection thermostat** (0 ÷ 150°C) The reference probe is the P3, the thermostat relay is given by the relay set as **oAi = Lin**.
- Lid:** **Differential for cooling injection thermostat** (0.1 ÷ 10.0) The reference probe is the P3

## 16.7 Fans regulation

- Pb** **Proportional band zone width** (00.10÷5.00bar/0.5÷30°C or 1÷80PSI/1÷50°F).  
**Set the dEU par. and the target set point for fans before setting this parameter.** The band is symmetrical compared to the target set point, with extremes: SETF+Pb/2 ÷ SETF -Pb/2. The measurement unit depends on the dEU par.
- ESF** **Energy saving value for fans:** (-20÷20bar; -50÷50°C) this value is add to the fans set point.

- Fon:** Time delay between the insertion of two different fans (0÷255sec).
- FoF:** Time delay between switching off of two different compressors (0÷255 sec)
- LSF:** Minimum set point for fan: The measurement unit depends on dEU parameter. It sets the minimum value that can be used for the set point, to prevent the end user from setting incorrect values.
- HSF:** Maximum set point for fan: The measurement unit depends on dEU parameter. It sets the maximum acceptable value for set point.
- MES:** Maximum value of the analog output during energy saving: (0÷100) it's used to limit the value of the analog output during energy saving.

## 16.8 Alarms – compressor section

- PAo:** Alarm probe exclusion at power on. it is the period starting from instrument switch on, before an alarm probe is signaled. (0÷255 min). During this time if the pressure is out of range all the compressor are switched on.
- LAL:** Low pressure (temperature) alarm – compressor section: The measurement unit depends on dEU parameter: (PA04 ÷ HAL bar; -50.0÷HAL °C; PA04÷HAL PSI; -58÷HAL °F) It's independent from the set point. When the value LAL is reached the A03C alarm is enabled, (possibly after the tAo delay time).
- HAL:** High pressure (temperature) alarm– compressor section: The measurement unit depends on dEU parameter: (LAL ÷ PA20 bar; LAL÷150.0 °C; LAL÷PA20 PSI; LAL÷302 °F). It's independent from the set point. When the value HAL is reached the A04C alarm is enabled, (possibly after the tAo delay time).
- tAo:** Low and High pressure (temperature) alarms delay– compressor section: (0÷255 min) time interval between the detection of a pressure (temperature) alarm condition and alarm signaling.
- ELP** Electronic pressure switch threshold: (-50°C÷SETC; -58°F÷SETC; PA04÷SETC); Pressure / Temperature value at which all the compressors are switched off. It has to be set some degrees above the mechanical low pressure switch value, in order to prevent mechanical low pressure activation.
- SEr:** Service request: (1÷9990 hours, res. 10h) number of running hours after that the “A14” maintenance call is generated.
- PEn:** Low pressure-switch intervention numbers: (0÷15). If the low pressure-switch is enabled PEn times in the PEI interval, the controller is locked. Only the manually unlocking is possible. See also the alarms table at paragraph 18. Every time the pressure-switch is enabled all the compressor are turned off.
- PEI:** Pressure-switch interventions time (0÷15 min) Interval, linked to the Pen parameter, for counting interventions of the low pressure-switch..
- SPr:** number of steps engaged with faulty probe. (0÷#compr).

## 16.9 Alarms – DLT section

- dtL** DGS discharge line alarm temperature (alarm always referred to P3 probe) (0÷180°C; 32÷356°F). If the probe 3 is used to detect the temperature of the discharge line of the DGS compressor, the compressor is switched off when this threshold is reached.
- dLd** DGS discharge line temperature alarm delay (alarm always referred to P3 probe) (0÷15min)
- dLH** DGS discharge line alarm reset differential (alarm always referred to P3 probe) (0.1÷25.5°C; 1÷50°F)

## 16.10 Alarms – fans section

- LAF:** Low pressure alarm – fans section: The measurement unit depends on the dEU parameter: (FA04 ÷ HAF bar; -50.0÷HAF °C; FA04÷HAF PSI; -58÷HAF °F) It's

independent from the set point. When the value LAF is reached the LA2 alarm is enabled, (possibly after the **AFd** delay time).

**HAF: High pressure alarm – fans section:** The measurement unit depends on the dEU parameter: (LAF=FA20 bar; LAF=150.0 °C; LAF÷FA20 PSI; LAF÷302 °F). It's independent from the set point. When the value HAF is reached the HA2 alarm is enabled, (possibly after the **AFd** delay time).

**AFd: Low and High pressure alarms delay – fans section:** (0÷255 min) time interval between the detection of a pressure alarm condition in the fans section and alarm signaling.

**HFC Compressors off with high pressure (temperature) alarm for fans**

**no** = compressors are not influenced by this alarm

**yES** = compressors are turned off in case of high pressure (temperature) alarm of fans

**dHF Interval between 2 compressors turning off in case of high pressure (temperature) alarm for fans** (0 ÷ 255 sec)

**PnF: High pressure-switch intervention numbers – fans section:** (0÷15 with 0 the manually unlocking is disabled) if the high pressure-switch is enabled PnF times in the PiF interval, the controller is locked. **It can be unlocked only manually.** See paragraph 18. Every time the pressure-switch is enabled all the compressors are turned off and all the fans are turned on.

**PiF: Pressure-switch interventions time – fans section** (1÷15 min) Interval, linked to the PEn parameter, for counting interventions of the high pressure-switch..

**FPr Number of fans engaged with faulty probe.** (0÷#fans).

## 16.11 Dynamic set point for fan

**dSEP Dynamic set point reference probe**

**nP** = no probe: dynamic set point disabled;

**P1**= P1 probe

**P2**= P2 probe

**P3**= P3 probe

**dSES External temperature value to start dynamic regulation** (-50÷150°C; -58÷302 °F)

**dSEb External band width for dynamic set point** (-50.0 ÷ 50.0°C; -90 ÷ 90°F)

**dSEd Set point differential for dynamic set point:** (-20.0÷20.0°C; -50.0÷50.0PSI; -300÷300°F)

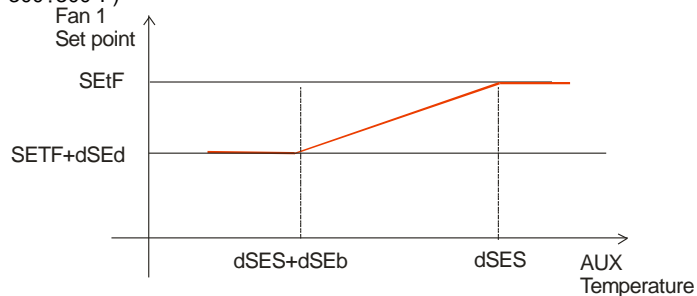

## 16.12 Analog output (optional)

**AoC Analog output setting**

**tEn** = 0÷10V output

**cUr** = 4-20mA output

**AOP Probe for analog output:**

**nP** = no probe;

**P1**= Probe 1;



P2= Probe 2

P3= Probe 3

**LAO Start of scale for analog output:** it's temperature (pressure) detected by the probe which is associated the 4mA or 0V value: (0.0÷51.0bar; -50.0÷150.0°C)

**UAO End of scale for analog output:** it's temperature (pressure) detected by the probe which is associated the 20mA or 10V value: (0.0÷51.0bar; -50.0÷150.0°C)

**AOm Minimum value for analog output** (4 ÷ 20mA)

**AOt Time of analog output at max after the start** (0÷15s)

**SAO Percentage of analog output in case of probe failure:** (0 ÷ 100%)

## 16.13 Other

**tbA Alarm relay silencing:** by pushing one of the keypad buttons. **no**= alarm relay stays on; **yES**= alarm relay is switched off by pushing any keys.

**OAP Alarm relay output polarity:** **cL**=closed when activated; **oP**= opened when activated

**oFF Switching ON/OFF enabling from keyboard:** (**no** = disabled; **yES**= enabled) It permits the switching ON/OFF of the instrument by pressing the SET key for more than 4s.

**Adr:** **Serial address** (1 –247) It is used in monitoring system.

**Ptb Parameter table code:** readable only.

**rEL Software release** for internal use.

## 17. Type of regulation

### 17.1 DIGITAL SCROLL REGULATION

The pressure is adjusted by a PI regulation.

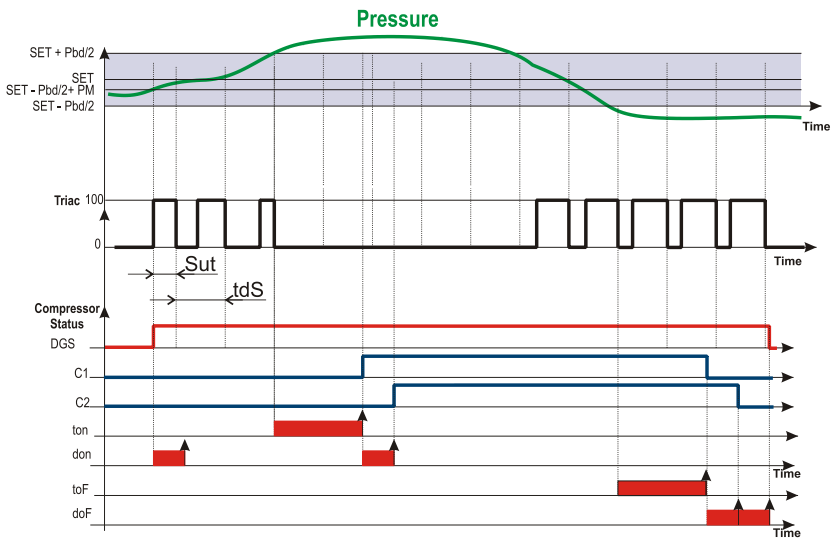

### **17.1.1 Regulation Start: increasing capacity**

- a. The regulation starts when the suction pressure (temperature) increases and reaches the value  $\text{SET-Pbd}/2+(\text{Pbd}\cdot\text{PM})/100$ . At first, if available, the digital compressor is powered, and it is modulated in PWM mode.  
**NOTE:** At start up the valve is energized for  $\text{SUt}$  seconds.
- b. Within the adjustment range ( $\text{SET-Pbd}/2 \div \text{SET}+\text{Pbd}/2$ ) the digital scroll compressor is activated in PWM mode in accordance with the value of the control variable. (NOTE: When the TRIAC is on the compressor is discharged; when the TRIAC is off the compressor is operative).
- c. When the pressure is greater than  $[\text{SET} + \text{Pbd}/2]$  and the TRIAC output is already at maximum, another compressor is started after the "ton" delay time.
- d. Then, if additional capacity is required (pressure higher than  $[\text{SET} + \text{Pbd}/2]$  another compressor starts after the "don" time.

**NOTE:** If the pressure exceeds the value  $\text{SET}+\text{Pbd}/2$  and the DGS compressor is not available (blocked by onon, oFon, safety digital input), another compressor is started (if available) in order to meet the adjustment request.

### **17.1.2 Decreasing capacity and regulation stop**

- a. When the pressure is lower than  $[\text{SET} - \text{Pbd}/2]$ , the DGS compressor is still modulated to minimum capacity for the toF time
- b. At the end of the toF time the load with more working hours is shut down. If the load must stay on because the donF time is not over yet, the next load is considered, and so on until a load that can be shut down is found or becomes available.
- c. This procedure continues with all active loads, with the shutdowns spaced out by the doF time setting.
- d. When only the DGS remains on, at the end of the doF time the DGS is shut down too.

### 17.1.3 Limitation of DGS compressor capacity by parameters PM and PMA

The capacity of the DGS compressor can be limited by the PM and PMA parameters, as shown in the following diagram.

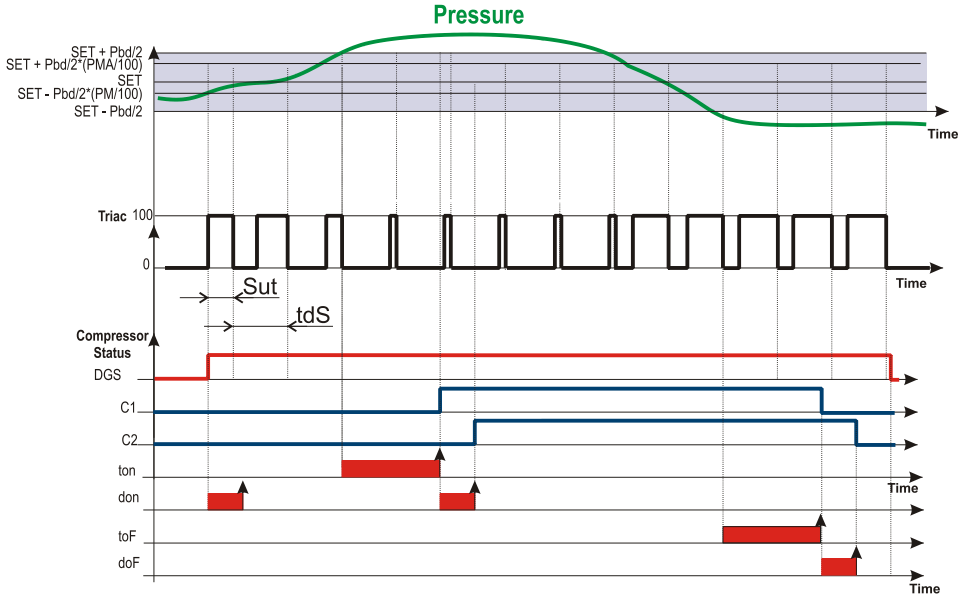

The capacity of the DGS compressor is limited by the PM and PMA parameters, where

**PM: in percentage, it sets the minimum capacity of the DGS activation during a period tdS.** For instance with  $tdS = 20s$  and  $PM = 20$ , the minimum activation of the DGS is 4s.

**NOTE:** for a proper functioning of the DGS, it's recommend a minimum activation time of 2s.

**PMA: it limits the percentage of the DGS activation during a tdS period according to the formula:  $((Pbd * PMA) / 100) * tdS$ .**

## 17.2 Proportional Band regulation - only for fans

The fan regulation band **Pb** is divided by the number of fans:

The numbers of fans switched ON is proportional to the value of the input signal: when this distance itself from the target set point and enters the various bands, the compressors are switched ON, to be then turned OFF when the signal brings near the set point.

In this way if the pressure is greater than regulation band, all the fans are on, if the pressure (temperature) is lower than the regulation band all the fans are off. Naturally also for this regulations all the delays (Fon and FoF) are valid.

### Regulation according to the running hours

The algorithm switch on and off the loads according to the running hours of each load. In this way the running hours are balanced.

#### Example

4 Fans: oA2 = FAn; oA3 = FAn; oA4 = FAn; oA6 = FAn:  
rot = yES rotation enabled

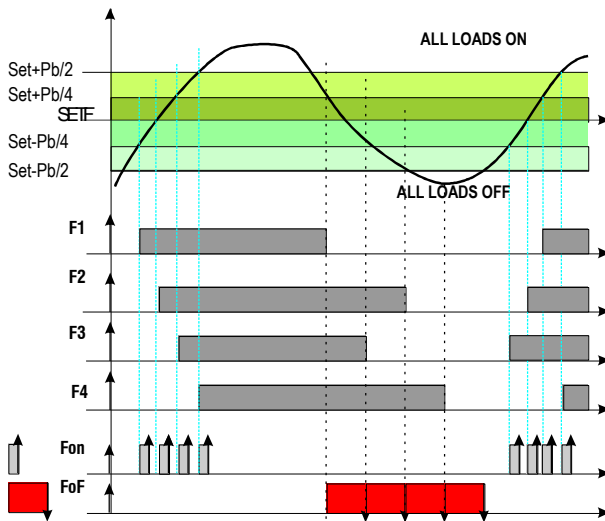

## 17.3 CONDENSER WITH INVERTER – Analog output setting

This configuration is used when all fans of the condensing group are driven by one inverter or a chopped phase driver.

The capacity used by the inverter is proportional to the delivery pressure value inside the regulation band ( $SETF-Pb/2 \div SETF+Pb/2$ ).

### 17.3.1 How to set it

Parameters involved:  $oA(i) = inF$ ;  $AoC = tEn$ ,  $AoP = P2$ ,  $AOM = 30$ ,

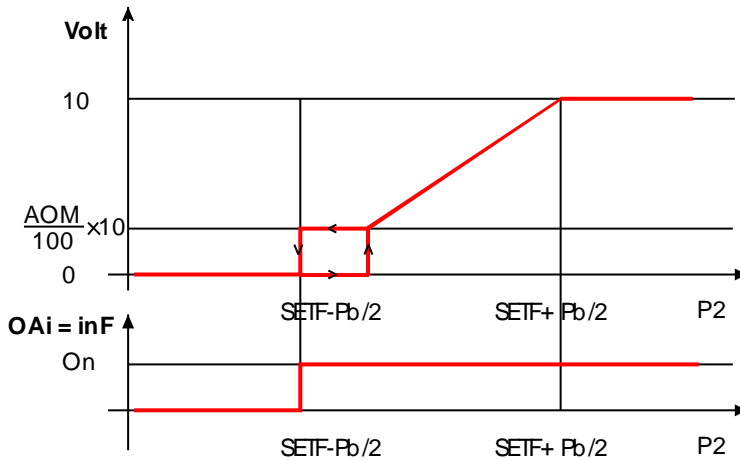

- Set a relay to drive the invert (is used to signal to the inverter to start and stop the regulation), by setting:  **$oA(i) = inF$**  inverter for fans
- Set the kind of signal of the analog output current (4-20ma) or voltage (0-10V) by the **Analog output setting** parameter "**AoC**": **tEn** = 0÷10V output; **cUr** = 4-20mA output
- Select the reference probe for the analog output (usually condenser probe P2) by the parameter **AOP**: **nP** = no probe; **P1**= Probe 1; **P2**= Probe 2 **P3**= Probe 3
- At last set also the percentage of analog output in case of probe failure: (0 ÷ 100%)**SAO**

## 18. Alarm list

Usually alarm conditions are signaled by means of:

1. Activation of alarm output 0-12V
2. Buzzer activation
3. Message on proper display
4. Log of alarm: code and duration.

The table at paragraph 18.3

### 18.1 Types of alarms and signaling managed

#### 18.1.1 A12: Configuration alarm

The following configuration parameters are checked after each modification.:

- OA2+ OA6** Outputs 2- 6 configuration
- P2P** Second probe presence.
- AOP** Probe for analog output

When these parameters are set in wrong way an alarm message is generated: the label **A12** is shown on the upper display, while the lower display the following messages are shown:

Mess.	Errata	Corrige
<b>Too Much dGS</b>	One oAi has been set as dGs (digital scroll)	<ul style="list-style-type: none"> <li>• Check the oAi parameters and set them different from dGS.</li> </ul>
<b>Too Much dGS</b>	One oAi has been set as dGst (triac for digital scroll)	<ul style="list-style-type: none"> <li>• Check the oAi parameters and set them different from dGS.</li> </ul>
<b>triac dGS out Error</b>	One oAi has been set as dGst (triac for digital scroll)	<ul style="list-style-type: none"> <li>• Check the oAi parameters and set them different from dGS.</li> </ul>
<b>triac dGS not PrESent</b>	One oAi has been set as dGs (digital scroll)	<ul style="list-style-type: none"> <li>• Check the oAi parameters and set them different from dGS.</li> </ul>
<b>dGS not PrESent</b>	One oAi has been set as dGst (triac for digital scroll)	<ul style="list-style-type: none"> <li>• Check the oAi parameters and set them different from dGS.</li> </ul>
<b>STEP ConFIG Error</b>	Load (step) configuration error	<ul style="list-style-type: none"> <li>• A relay oA(i) has been set as compressor without a previous relay oA(i-1) has been set as compressor. EI oA1 = StP</li> </ul>
<b>no P3 Probe PrESent</b>	The P3 probe is requested for a function, but it's not present	<ul style="list-style-type: none"> <li>• Check the parameters P3C</li> </ul>
<b>no LoAdS For rEGuLAtion</b>	None oA(i) is set as compressors or fans	<ul style="list-style-type: none"> <li>• Check the setting of oA2, oA3, oA4, oA6 parameters</li> </ul>
<b>AOP2</b>	P2 probe not available for the 4÷20mA output	<ul style="list-style-type: none"> <li>• P2 probe not available P2P =no. Enable the probe setting: P2P =yES</li> <li>• The second probe P2 is used to</li> </ul>

Mess.	Errata	Corrige
		control the temperature of the engine of screw compressors. Check CtyP and set it different from Scr.
<b>ProbE tyPE For dynAMic Set</b>	Wrong setting of the probe for dynamic set point	<ul style="list-style-type: none"> <li>The probe for dynamic set point dSEP par. has to be set as temperature probe</li> </ul>
<b>no FAn ProbE</b>	P2 probe not available for fan regulation	<ul style="list-style-type: none"> <li>P2 probe not available P2P =no. Enable the probe setting: P2P =yES</li> <li>The second probe P2 is used to control the temperature of the engine of screw compressors. Check CtyP and set it different from Scr.</li> </ul>

### **18.1.2 E01L, Electronic Pressure switch alarm, suction section**

#### **Parameters**

**ELP: Electronic pressure switch threshold:** (-50°C÷SETC; -58°F÷SETC; PA04÷SETC); Pressure / Temperature value at which all the compressors are switched off. It has to be set some degrees above the mechanical low pressure switch value, in order to prevent mechanical low pressure activation.

#### **Actions**

**Electronic low pressure:** every time the suction temperature/pressure is less than ELP value all the compressors are switched off. The instrument restarts the standard operating mode when pressure/ temperature increases.

### **18.1.3 E0H, E0L Pressure switch alarm, suction and condensing sections**

#### **Terminals**

Low pressure switch input: 9-10, high pressure switch input: HP [25-26].

#### **Parameters**

**I3P: Low pressure switch polarity:** It establishes if the input is activated by closing (I3P=cL) or by opening (I3P=oP) the terminals.

**I4P: High pressure switch polarity:** It establishes if the input is activated by closing (i4P=cL) or by opening (i4P =oP) the terminals.

#### **Actions**

**Low pressure:** every time the inputs are activated all the compressors are switched off. The instrument restart the standard operating mode when the input is disabled. If there are PEN activation in the PEi time, only manual resetting is allowed, by pressing the **DOWN** key for 3s or by turning off and on the instrument.

**High pressure:** every time the inputs are activated all the compressors are switched off and fans are switched on. The instrument restart the standard operating mode when the input is disabled. If there are PnF activation in the PiF time, only manual resetting is allowed, by pressing the **DOWN** key for 3s or by turning off and on the instrument.

### **18.1.4 EA1÷EA6: Compressors and fans safeties alarm.**

#### **Terminals**

**WARNING: THESE TERMINALS REQUIRE A FREE OF VOLTAGE CONNECTION.**

The terminals (from 10, 11, 12, 13, 14+ ID5) really used depends on the number of loads. The protections regarding the compressors and fans are connected to these inputs. If one of these protections is enabling (E.I. for lack of oil or overheating, etc.) the corresponding load is turn off.

#### **Parameters**

**ALIP:** It establishes if the input is activated by closing (ALIP=cL) or by opening (ALIP=oP) the terminals.

#### **Actions**

Every time one input is activated the corresponding output is turned off.

#### **Recovery**

Recovery depends on **ALMr** parameter:

With **ALMr = no** The instrument restart the standard operating mode when the input is disabled.

With **ALMr = yES** manual recover for the alarms of compressors and fans. Push the **DOWN** key for 3s.

### **18.1.5 P1, P2; P3: probe failure alarm**

It is generated by failure in the probe P1, P2 or P3.

In case of **P1** fault, number of steps engaged depends on the **SPr** parameter

In case of **P2** fault, number of fans engaged depends on the **FPr** parameter

#### **If the P3 probe is used for dynamic set point**

The function is disabled and only the standard set point is used.

#### **If the P3 probe is used for analog output**

The function is disabled, the value of the analog output is set in the **SAo** parameter.

#### **Recovery**

Automatic as soon as probe restarts working.

### **18.1.6 C-HA, C-LA, F-HA, F-LA High and low pressure (temperature) alarms for compressors or fans**

This alarm signals that the pressure (temperature) is out of limits established by parameters **LAL** and **HAL** for compressors and **LAF –HAF** for fans.

The **tAo** and **AFd** parameters set the delay between alarm condition and alarm signaling.

#### **Action**

The alarm is signaled with standard action. The outputs are unchanged.

## **18.2 Buzzer muting**

Press any buttons to silence the buzzer during an alarm condition.

Hold pressed for more than 3 seconds switch off the alarm relay during an alarm condition



## 18.3 Alarm conditions – summary table

Code	Description	Cause	Action	Reset
E01L	Low electronic pressure-switch alarm	Pressure/temperature less than ELP value	All compressors are turned off. Fans unchanged.	<b>Automatically</b> when the pressure/temperature increases more than ELP value
E0L	Low pressure-switch alarm	Low pressure switch input enabled	All compressors are turned off. Fans unchanged.	<p><b>Automatically</b> (if the number of activation are less than PE<sub>n</sub> in the PE<sub>i</sub> time) when the input is disable.</p> <ul style="list-style-type: none"> <li>- The compressors restarts working according to the working algorithm.</li> </ul> <p><b>Manually</b> (if PE<sub>n</sub> activation happened in the PE<sub>i</sub> time) When the input is disable:</p> <ol style="list-style-type: none"> <li>a. hold pressed the <b>Restart(DOWN)</b>key for 3s or</li> <li>b. turn off and on the instrument..</li> </ol> <ul style="list-style-type: none"> <li>- The compressors restarts working according to the working algorithm.</li> </ul>
E0H	High pressure switch alarm	High pressure switch input enabled	<ul style="list-style-type: none"> <li>- All compressors are turned off.</li> <li>- All fans are turned on.</li> </ul>	<p><b>Automatically</b> (if the number of activation are less than PE<sub>n</sub> in the PE<sub>i</sub> time) when the input is disable.</p> <ul style="list-style-type: none"> <li>- Compressors and fans restart working according to the working algorithm.</li> </ul> <p><b>Manually</b> (if PE<sub>n</sub> activation happened in the PE<sub>i</sub> time) When the input is disable:</p> <ul style="list-style-type: none"> <li>- hold pressed the <b>Restart(DOWN)</b> key for 3s or</li> <li>- turn off and on the instrument.</li> </ul> <p>Compressors and fans restarts working according to the working algorithm.</p>
P1	P1 probe failure alarm	Probe failure or out of range	<ul style="list-style-type: none"> <li>- The compressors are activated according to the SP<sub>r</sub> or PoPr parameters.</li> </ul>	<b>Automatically</b> as soon as the probe restarts working.
P2	P2 probe failure alarm	Probe failure or out of range	<ul style="list-style-type: none"> <li>- The fans are activated according to the FPr parameters.</li> </ul>	<b>Automatically</b> as soon as the probe restarts working.
P3	P3 probe failure alarm	Probe failure or out of range	<ul style="list-style-type: none"> <li>- The functions related to the third probe are disabled.</li> </ul>	<b>Automatically</b> as soon as the probe restarts working.

Code	Description	Cause	Action	Reset
EA1 EA2 EA3 EA4 EA5 EA6	Load safeties alarm	Safeties compressor/fan input activation. NOTE: with step compressors 1 input for each compressor has to be used.	– the corresponding load is turned off. (with step compressors all relays referred to the input are disabled).	Recovery depends on <b>ALMr</b> parameter: With <b>ALMr = no</b> The instrument restart the standard operating mode when the input is disabled. With <b>ALMr = yES</b> manual recover for the alarms of compressors and fans. Push the <b>DOWN</b> key for 3s.
C-LA	Minimum pressure (temperature) alarm compressors section	Suction pressure or temperature lower than LAL value	– signaling only	<b>Automatically:</b> as soon as the pressure or temperature reaches the (LAL+ differential) value. (differential = 0.3bar or 1°C)
F-LA	Minimum pressure (temperature) alarm fans section	Condensing pressure or temperature lower than LAF value	– signaling only	<b>Automatically:</b> as soon as the pressure or temperature reaches the (LAF+ differential) value. (differential = 0.3bar or 1°C)
C-HA	Maximum pressure (temperature) alarm compressors section	Suction pressure or temperature higher than HAL value	– signaling only	<b>Automatically:</b> as soon as the pressure or temperature reaches the (HAL - differential) value. (differential = 0.3bar or 1°C)
F-HA	Maximum pressure (temperature) alarm fans section	Condensing pressure or temperature higher than HAF value	– Depends on the parameter HFC	<b>Automatically:</b> as soon as the pressure or temperature reaches the (HAF - differential) value. (differential = 0.3bar or 1°C)
A5	Liquid level alarm	Input enabled	– signaling only	<b>Automatically</b> as soon as the input is disabled
A12	Configuration alarms	See par. 18.1	–	
A14	Load maintenance alarm	A load has worked for the hour set in the SEr parameter	- signaling only	<b>Manually:</b> reset the running hour of the compressor (see par.12 <b>Running hours of loads</b> )
dtL	Discharge Line Temperature	Pb3 Temperature Higher than <b>dtL</b> for the <b>dLd</b> time delay	Digital Scroll switched off	<b>Automatically</b> as soon as the temperature becomes lower than <b>dtL</b> .

## 19. Technical features

**Housing:** Self extinguishing ABS.

**Case:** Front panel 32x74 mm, depth 70mm ("CX" format);

**Mounting:** "CX" format panel mounting in a 29x71 mm panel cut-out

**Protection:** IP20.

**Frontal protection:** IP65.

**Connections:** Removable terminal block 6 and 14 ways;

**Power supply:** 12Vac/dc  $\pm$  10%, 24Vac/dc  $\pm$  10%, 50-60Hz.

**Power absorption:** 5VA max.

**Display:** 4 digits red led and 4 digit orange led.

**Inputs:** 2 NTC probes, or 2 PTC probes and 2 4..20mA transducer.

**Digital inputs:** 7 free voltage

**Relay outputs:** 4 relay SPST 5(3)A, 250Vac

**Triac output:** 0,5A 230V

**oA6 open collector:** output: 12V, 40mA.

**Analogue output:** 4÷20mA or 0÷10V,

**Serial output :** TTL standard **Communication protocol:** ModBus – RTU

**Data storing:** on the non-volatile memory (EEPROM).

**Kind of action:** 1B; **Pollution grade:** normal; **Software class:** A.

**Operating temperature:** -10÷60 °C.; **Storage temperature:** -25÷60 °C.

**Relative humidity:** 20÷85% (no condensing)

**Measuring range: NTC probe:** -40÷110°C.

**Resolution:** 0,1 °C; 1°F; 0.1bar; 1 PSI;

**Accuracy (ambient temp. 25°C):**  $\pm$ 0,7 °C  $\pm$ 1 digit

## 20. Parameters – Default values

Name	Value	Level	Description	Range
SEtc	-10.0	Pr1	Set point for compressors	LSE ÷ HSE
SEtF	35.0	Pr1	Set point for fans	LSF ÷ HSF
OA2	CPr	Pr2	Load 2 configuration	nu - CPr - FAn - StP - dGS - dGSt - LIn - InF - ALr
OA3	FAn	Pr2	Load 3 configuration	nu - CPr - FAn - StP - dGS - dGSt - LIn - InF - ALr
OA4	FAn	Pr2	Load 4 configuration	nu - CPr - FAn - StP - dGS - dGSt - LIn - InF - ALr
OA6	ALr	Pr2	Load 6 configuration	nu - CPr - FAn - StP - dGS - dGSt - LIn - InF - ALr
FtyP	407F	Pr2	Freon Type	r22; 404A; 407A; 407C; 407F; 410A; r507; r134; co2 = CO2 (carbon dioxide)
rty	db	Pr2	Type of regulation: neutral zone or proportional band	db - Pb
Sty	YES	Pr2	Compressor Sequence type	no - yES
rot	YES	Pr2	Fan Sequence type	no - yES
P1C	Cur	Pr2	P1 probe setting (4/20mA, 0-5V, ntc)	nP - Cur - tEn - ntc
PA04	-0.5	Pr2	4mA or 0.5V readout for P1 probe	(-1.0 ÷ PA20)BAR (-15 ÷ PA20)PSI; (-100 ÷ PA20)KPA
PA20	11.0	Pr2	20mA or 4.5V readout for P1 probe	(PA04 ÷ 51.0) <sup>BAR</sup> (PA04 ÷ 750) <sup>PSI</sup> (PA04 ÷ 5100) <sup>KPA</sup>
CAL	0.0	Pr2	P1 probe offset	(dEU=bar o °C) -12.0 ÷ 12.0(dEU=PSI o °F) -20 ÷ 20; (dEU=kPA) -120 ÷ 120;
FPb	P2	Pr2	Probe for fan	nP; P1, P2
P2C	Cur	Pr2	P2 probe setting (4/20mA, 0-5V, ntc)	nP - Cur - tEn - ntc
FA04	0.0	Pr2	4mA or 0.5V readout for P2 probe	(-1.0 ÷ FA20) <sup>BAR</sup> (-15 ÷ FA20) <sup>PSI</sup> (-100 ÷ FA20)KPA
FA20	30.0	Pr2	20mA or 4.5V readout for P2 probe	(FA04 ÷ 51.0) <sup>BAR</sup> (FA04 ÷ 750) <sup>PSI</sup> (FA04 ÷ 5100)KPA
FCAL	0.0	Pr2	P2 probe offset	(dEU=bar o °C) -12.0 ÷ 12.0(dEU=PSI o °F) -20 ÷ 20
P3C	nP	Pr2	P3 probe setting (NTC 10K, NTC 86K)	nP - 10 - 86
O3	0.0	Pr2	P3 probe offset	(dEU=°C) -12.0 ÷ 12.0(dEU=°F) -20 ÷ 20
i2F	LL	Pr1	2nd digital input configuration	id5 - id6 - LP - HP - ES - OFF - LL
i1P	cL	Pr2	1st digital/analog input polarity	OP - CL
i2P	cL	Pr2	2nd digital input polarity	OP - CL
i3P	cL	Pr2	3rd digital input polarity	OP - CL
i4P	cL	Pr2	4th digital input polarity	OP - CL
did	20	Pr1	Configurable digital input delay	0 ÷ 255 (min.)
ALIP	cL	Pr2	id1-1d4 alarm input for compressors and fans polarity	OP - CL
ALMr	no	Pr2	Manual reset for compressor/fan alarms	no - yES
dEU	tPr	Pr2	Displaying measurement unit: pressure or temperature	tMP - PrS
CF	°C	Pr2	Measurement unit for temperature	°C - °F

Name	Value	Level	Description	Range
PMU	Bar	Pr2	Measurement unit for pressure	Bar - PSI - PA
rES	dE	Pr2	Resolution for display and parameters	in - dE
dFE	no	Pr2	Pressure filter enabling	no - yES
dEU1	tPr	Pr2	Upper display: pressure or temperature selection	tMP - PrS
dSP2	P2	Pr2	Variable to show on the lower display	nu(0) - P1(1) - P2(2) - P3(3) - SEt1(4) - SEt2(5)
dEU2	tPr	Pr2	Lower display: pressure or temperature selection	tMP - PrS
Pbd	5.0	Pr2	Proportional band for compressors regulation	(BAR) 0.1÷10.0 (°C) 0.1÷30.0 (PSI) 1÷150 (°F) 1÷50 [-12.0°C ÷ 12.0°C] [-12°C ÷ 12°C] [-21°F ÷ 21°F]
rS	0.0	Pr2	Band offset	
inC	500	Pr2	Integral time	0 ÷ 999 s
SUt	2	Pr2	Digital input valve on at start up	0÷3s
tdS	15	Pr2	Cycle time for digital compressor	10÷40s
PM	30	Pr2	Minimum capacity for digital compressor	10÷PMA
PMA	100	Pr2	Maximum capacity for digital compressor	PM÷100
ton	60	Pr2	Time with digital compr. at PMA value before starting a load	0÷255s
toF	5	Pr2	Time with digital compr. at PM before turning off a load	0÷255s
MinP	0	Pr2	Minimum capacity threshold to start the safety lubrication function	0÷100
tMin	180	Pr2	Max time at MinP to start the safety lubrication function	1÷255min
tMAS	3	Pr2	Time at PMA for digital compressor to restore the right lubrication	1÷255min
HPP	50	Pr1	DGS capacity with "dLT" and "HA2" alarm	0÷PMA (%)
ESC	0.0	Pr1	Energy saving for compressors regulation	(BAR) -20.0÷20.0 (°C) -50.0÷50.0 (PSI) -300÷300 (°F) -90÷90
OnOn	5	Pr2	Minimum delay between 2 switching on of the same compressor	0 ÷ 255 (min.)
OFOOn	1	Pr2	Delay between the switching off and on of the same compressor	0 ÷ 255 (min.)
don	01:00	Pr2	Time delay between the insertion of two different loads	0 ÷ 99.5 (min.10sec)
doF	00:10	Pr2	Time delay between switching off of two different compressors	0 ÷ 99.5 (min.10sec)
donF	00:30	Pr2	Minimum time a stage stays ON	0 ÷ 99.5 (min.10sec)
MAon	0	Pr2	Maximum time a stage stays switched ON	0 ÷ 24 (ore)
FdLy	no	Pr2	'don' delay enabled also for the first request	no - yES
FdLF	no	Pr2	'doF' delay enabled also for the first switching off	no - yES
odo	20	Pr2	Regulation delay at power on	0 ÷ 255 (sec.)
LSE	-40.0	Pr2	Minimum set point (compressors)	<b>BAR:</b> (PA04÷HSE)abs; ((PA04-1.013)÷HSE)rel <b>°C:</b> -50.0÷HSE <b>PSI:</b> (PA04÷HSE)abs; ((PA04-14)÷HSE)rel <b>°F:</b> -58.0 ÷ HSE
HSE	10.0	Pr2	Maximum set point (compressors)	<b>BAR:</b> (LSE+PA20)abs, (LSE÷(PA20-1.013))rel <b>°C:</b> LSE ÷ 150 <b>PSI:</b> (LSE ÷ PA20)abs (LSE÷(PA20-14))rel <b>°F:</b> LSE ÷ 302
Lit	90.0	Pr2	Set point for probe 3	0.0 ÷ 180.0(°C) 32 ÷ 356(°F)
Lid	10.0	Pr2	Differential for probe 3	0.1 ÷ 25.5° (°C)1 ÷ 50° (°F)

Name	Value	Level	Description	Range
Pb	5.0	Pr2	Proportional band for fan regulation	(BAR)0.1÷10.0; (°C)0.1÷30.0; (PSI)1÷150; (°F) 1÷50
ESF	0.0	Pr2	Energy saving differential for fan regulation	(BAR) -20.0÷20.0 (°C) -50.0÷50.0 (PSI) -300÷300 (°F) -90÷90
Fon	30	Pr2	Time delay between the insertion of two different fan	0 ÷ 255 (sec)
FoF	15	Pr2	Time delay between switching off of two different fan	0 ÷ 255 (sec)
LSF	10.0	Pr2	Minimum set point (fan)	<b>BAR:</b> (FA04÷HSF)abs ((FA04-1.01)÷HSF)rel °C: -50.0÷HSF <b>PSI :</b> (FA04 ÷ HSF)abs((FA04-14) ÷ HSF)rel °F : -58.0 ÷ HSF
HSF	50.0	Pr2	Maximum set point (fan)	<b>BAR :</b> (LSF ÷ F20)abs (LSF ÷ (F20-1.013))rel °C: LSF ÷ 150.0 <b>PSI :</b> (LSF ÷ FA20)abs (LSF÷(FA20 - 14))rel °F: LSF ÷ 302
	100	Pr2	Max value of analog output during Energy saving	0 ÷ 100 (%)
PAO	30	Pr2	Alarm probe delay at power on	0 ÷ 255 (min.)
LAL	-40.0	Pr1	Pressure alarm set low limit (compressors)	(PA04 ÷ HAL) <sup>BAR</sup> (-50.0 ÷ HAL) <sup>°C</sup> (PA04 ÷ HAL) <sup>PSI</sup> (-58 ÷ HAL) <sup>°F</sup>
HAL	10.0	Pr1	Pressure alarm set high limit (compressors)	(LAL ÷ PA20) <sup>BAR</sup> (LAL ÷ 150.0) <sup>°C</sup> (LAL ÷ PA20) <sup>PSI</sup> (LAL ÷ 302) <sup>°F</sup>
tAo	15	Pr1	Pressure/temperature alarm delay (compressors)	0 ÷ 255 (min.)
ELP	-45.0	Pr2	Electronic pressure switch threshold	(PA04 ÷ SETC) <sup>BAR</sup> (-50.0 ÷ SETC) <sup>°C</sup> (PA04 ÷ SETC) <sup>PSI</sup> (-58 ÷ SETC) <sup>°F</sup>
SEr	999	Pr2	Working our alarm set (tenth of ours)	1 ÷ 999 (0= ESCLUSO) (10 ore)
PEn	5	Pr2	Pressure switch maximum activations	0 ÷ 15
PEI	60	Pr2	Pressure switch activations time	0 ÷ 255 (min.)
SPr	1	Pr2	Compressors ON with faulty probe	0 ÷ (nCPR)
dtL	110.0	Pr2	DLT high temperature alarm threshold	0÷180°C/32÷356°F
dLd	5	Pr2	DLT high temperature alarm delay	0÷15min
dLH	15.0	Pr2	DLT high temperature alarm differential for recovery	0.1÷25.5°C//1÷50°F
LAF	0.0	Pr1	Low pressure alarm set (fan)	(FA04 ÷ HAF) <sup>BAR</sup> (-50.0 ÷ HAF) <sup>°C</sup> (FA04 ÷ HAF) <sup>PSI</sup> (-58 ÷ HAF) <sup>°F</sup>
HAF	60.0	Pr1	High pressure alarm set (fan)	(LAF ÷ FA20) <sup>BAR</sup> (LAF ÷ 150.0) <sup>°C</sup> (LAF ÷ FA20) <sup>PSI</sup> (LAF ÷ 302) <sup>°F</sup>
AFd	5	Pr2	Pressure alarm delay	0 ÷ 255 (min)
HFc	YES	Pr2	Compressor off with high pressure (temperature) alarm	no - yES
dHF	5	Pr2	Interval between 2 compressors turning off with high pressure (temperature) alarm	1÷255s
PnF	5	Pr2	Fan pressure switch maximum activations	0 ÷15
PiF	60	Pr2	Fan pressure switch activations time	0 ÷ 255 (min)
FPr	1	Pr2	Fan ON with faulty probe	0 ÷ (nFAN)
dSEP	nP	Pr2	Dynamic Set point function enabled	nP - P1 - P2 - P3
dSES	35.0	Pr2	External temperature set for DYNAMIC SET POINT function	-50.0 ÷ 150.0 (°C) -58 ÷ 302 (°F)
dSEb	10.0	Pr2	Proportional band DYNAMIC SET POINT	-50.0 ÷ 50.0(°C) -90 ÷ 90 (°F)
dSEd	0.0	Pr2	Differential for DYNAMIC SET POINT	(BAR) -20.0÷20.0 (°C) -50.0÷50.0 (PSI) -300÷300 (°F) -90÷90

Name	Value	Level	Description	Range
AOC	Cur	Pr2	Analogue output working mode	Cur - tEn
AOP	nP	Pr2	Probe for analogue output	nP - P1 - P2 - P3
LAO	-50.0	Pr2	Lower scale limit for analogue output	$0.0 \div 51.0^{(\text{BAR})}$ - $50.0 \div 150.0^{(\text{°C})} 0 \div 750^{(\text{PSI})}$ - $58 \div 302^{(\text{°F})}$
UAO	60.0	Pr2	Upper scale limit for analogue output	$0.0 \div 51.0^{(\text{BAR})}$ - $50.0 \div 150.0^{(\text{°C})} 0 \div 750^{(\text{PSI})}$ - $58 \div 302^{(\text{°F})}$
AOM	40	Pr2	Minimum value of analogue output	0 ÷ 100
AOt	5	Pr2	Time with analog output at max when after exceeding AOM	0 ÷ 15s
SAO	80	Pr2	Percentage of analog output in case of probe failure	0 ÷ 100
tbA	YES	Pr1	Alarm relay silencing	no - yES
OAP	cL	Pr2	Polarity alarm relay	OP - CL
oFF	no	Pr2	off function enabled	no - yES
Adr	1	Pr2	Serial address	1 ÷ 247
rEL	2.9	Pr2	Release firmware	Readable only
Ptb	-	Pr2	Parameter table code	Readable only
Pr2	3210	Pr1	Pr2 access	Readable only

**Dixell**



**Dixell S.r.l.** - Z.I. Via dell'Industria, 27 - 32010 Pieve d'Alpago (BL) ITALY  
Tel. +39.0437.9833 r.a. - Fax +39.0437.989313 - EmersonClimate.com/Dixell - dixell@emerson.com